

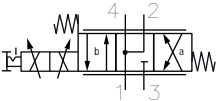
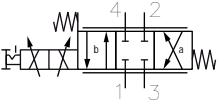

Proportional Valves

	MODEL	DESCRIPTION	FLOW	CAVITY
	PDFC-4M	4/3 PROPORTIONAL DIRECTIONAL VALVE	8 GPM	C1040
	PDFC-4L			
	EPRR-10	PROPORTIONAL PRESS. REDUCING/RELIEVING	1 GPM	C1030
	EPRT-08	PROPORTIONAL PRESS. REDUCING/RELIEVING	7 GPM	C0830/AM
	EPRS-10 EPRS-12	PROP. P.O. PRESSURE REDUCING/RELIEVING	12 GPM 24 GPM	C1030 C1230
	ERVP-10 ERVP-12	PROPORTIONAL P.O. PRESSURE RELIEF	25 GPM 60 GPM	C1020 C1220
	ERVD-10	PROPORTIONAL PRESS. RELIEF, LOW FLOW	1 GPM	C1020
	EPFI-10 EPFI-12 EPFC-16	PROPORTIONAL PRESS. COMP. FLOW CONTROL	8 GPM 15 GPM 20 GPM	C1020 C1220 C1620
	EPFB-10 EPFB-12 EPFD-16	PROP. PRIORITY PRESS. COMP. FLOW CONTROL	8 GPM 15 GPM 20 GPM	C1030 C1230 C1630
	PFCV-10 PFCV-12 PFCV-16	PROPORTIONAL NON-COMP. FLOW CONTROL	16 GPM 24 GPM 36 GPM	C1020 C1220 C1620

Proportional Valves

	MODEL	DESCRIPTION	FLOW	CAVITY
	MDR32GN	PROPORTIONAL 3/2 THROTTLE CARTRIGE	8 GPM	AM
	MDR42A	PROPORTIONAL 4 /2 THROTTLE CARTRIGE	8 GPM	AN
	MVRPSBA-2G	PROPORTIONAL THR OTTLE CARTRIGE	13 GPM	C0820/AL
	PIFC-10 PIFC-12 PIFC-16	PROP. FLOW CONTROL WITH COMPENSATOR	16 GPM 24 GPM 36 GPM	C1020 C1220 C1620
	PBFC-10 PBFC-12 PBFC-16	PROP. PRIORITY FLOW CONTROL WITH COMP.	16 GPM 24 GPM 36 GPM	C1030 C1230 C1630
	PWM-1400 PWM-1401 PWM-1404	PWM MICRO PROPORTIONAL VALVE DRIVER PWM PROPORTIONAL DRIVER, COIL MOUNTED PWM PROPORTIONAL DRIVER CONTROL BOX		

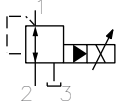
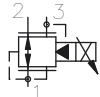
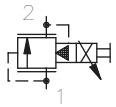
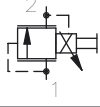
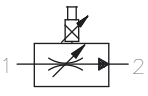
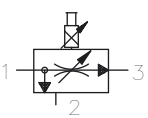
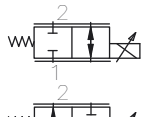
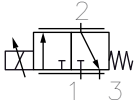
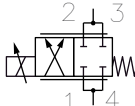
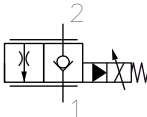
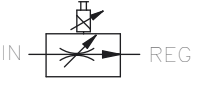
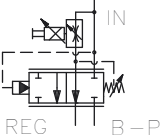
4/3 Proportional Directional Valve, Size SAE 10

$Q_{\max} = 8.0 \text{ gpm [30 l/min]}$, $p_{\max} = 4000 \text{ psi [280 bar]}$
Direct acting, sliding-spool design, with solenoid operation
Series PDFC-10...



- Compact construction for cavity type C1040 – 7/8-14 UNF
- Operated by a proportional high pressure wet-armature solenoid
- Minimum current threshold/ dead band (position b) is factory set for better consistency
- Manual over-ride optionally available, detented in neutral position
- Excellent reproducibility and repeatability, and low hysteresis
- All exposed parts with zinc-nickel plating
- The slip-on coil can be rotated, and it can be replaced without opening the hydraulic envelope
- Various plug-connector systems and voltages are available
- Can be fitted in a line-mounting body

1 Description

Series PDFC-10... proportional directional valves are direct acting screw-in cartridges with a sliding spool design and a 7/8-14 UNF mounting thread. In the neutral position, port 3 is closed and depending on the spool type, ports 2 and 4 are connected to tank (1) (spool configuration M) or ports 1, 2 and 4 are all blocked (spool configuration L). The version with the M spool is used in motor control circuits where free-wheeling in the neutral position is required. The L configuration is the version to use for cylinder applications. These cartridges are particularly suitable for precise and controlled lifting and lowering movements and can also be used for reliable operation in mobile and industrial applications. Best controllability is achieved when using the valve with a bypass pressure compensator to control pressure drop through the valve. Using the valve without pressure

compensator is not recommended because higher pressure drops cause the flow to be more restricted (see performance graph). The proportional directional valve is optionally equipped with a manual over-ride which is detented in the neutral position. To unlatch the detent mechanism, the button on the back can be pushed. That allows shifting the valve in both directions. Pushing the knob shifts the valve to position (a) (3→2 and 4→1) and pulling shifts it to position (b) (3→4 and 2→1). All external parts of the cartridge are zinc plated and chromited (CrVI-free). The slip-on coils can be replaced without opening the hydraulic envelope and can be positioned at any angle through 360°. If you intend to manufacture your own cavities or are designing a line-mounting installation, please refer to the section "Related data sheets".

2 Symbol

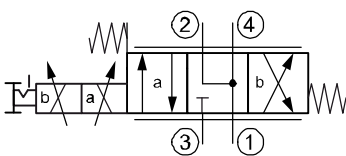

PDFC-10-...-4M-M...

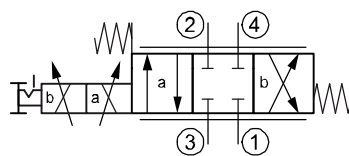

PDFC-10-...-4L-M...

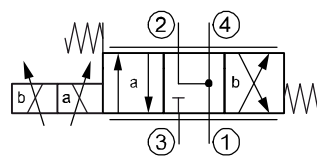

PDFC-10-...-4M-0...

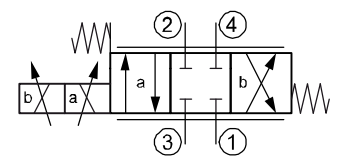

PDFC-10-...-4L-0...

3 Technical data

General characteristics		Description, value, unit	
Designation		4/3 proportional directional valve	
Design		sliding-spool design, direct acting, with solenoid operation	
Mounting method		screw-in cartridge 7/8-14 UNF	
Tightening torque		40...45 ft-lbs	[54...61 Nm]
Size		size SAE 10, cavity type C1040	
Weight		1.65 lbs	[0.75 kg]
Mounting attitude		unrestricted (preferably vertical, coil down)	
Ambient temperature range		-15 °F ... +125 °F	[-25 °C ... +50 °C]
Hydraulic characteristics		Description, value, unit	
Maximum operating pressure	- ports 2, 3, 4 - port 1	4000 psi 2000 psi	[280 bar] [140 bar]
		higher pressure, please consult BUCHER	
Maximum flow rate	- port 3 → 4 and 2 → 1 - port 3 → 2 and 4 → 1	7.0 gpm at Δp 140 psi 6.2 gpm at Δp 140 psi at 100% duty cycle	[26 l/min at Δp 10 bar] [24 l/min at Δp 10 bar]
Leakage flow rate	(port to port)	15 inch ³ at 3000 psi	[245 ml/min at 210 bar]
Hydraulic fluid		HL and HLP mineral oil to DIN 51 524; for other fluids, please contact BUCHER	
Hydraulic fluid temperature range		-15 °F ... +160 °F	[-25 °C ... +70 °C]
Viscosity range		15...380 mm ² /s (cSt), recommended 20...130 mm ² /s (cSt)	
Minimum fluid cleanliness Cleanliness class to ISO 4406 : 1999		class 18/16/13	
Electrical characteristics		Description, value, unit	
Supply voltage		12 V DC, 24 V DC	
Control current		12 V = 0...1400 mA, 24 V = 0...750 mA (100% duty cycle) 12 V = 0...1600 mA, 24 V = 0...880 mA (50% duty cycle)	
Power consumption at max. control current		max. 19 W	
Coil resistance R	- cold value at 20 °C - max. warm value	12 V = 5.8 Ω / 24 V = 20.9 Ω 12 V = 9.1 Ω / 24 V = 32.7 Ω	
Recommended PWM frequency (dither)		200 Hz	
Hysteresis with PWM		2...5 % I _N	
Reversal error with PWM		2...5 % I _N	
Sensitivity with PWM		< 1.5 % I _N	
Reproducibility with PWM		< 3 % p _N	
Relative duty cycle		100 % / 50 %	
Protection class to ISO 20 653 / EN 60 529		IP 65 / IP 67 / IP 69K, see "Ordering code" (with appropriate mating connector and proper fitting and sealing)	
Electrical connection		3-pin square plug to ISO 4400 / DIN 43 650 (standard) for other connectors, see "Ordering code"	

4 Performance graphs

Q = f (I; Δp) Flow rate adjustment characteristic 4M

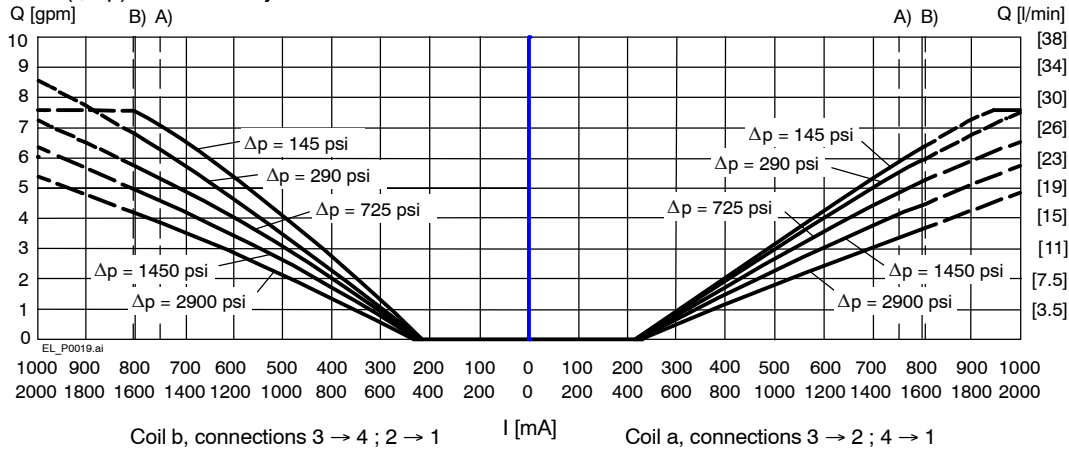

A) 100% duty cycle

B) 50% duty cycle

--- depending on coil temperature, solenoid may draw a voltage higher than the nominal voltage

Q = f (I; Δp) Flow rate adjustment characteristic 4L

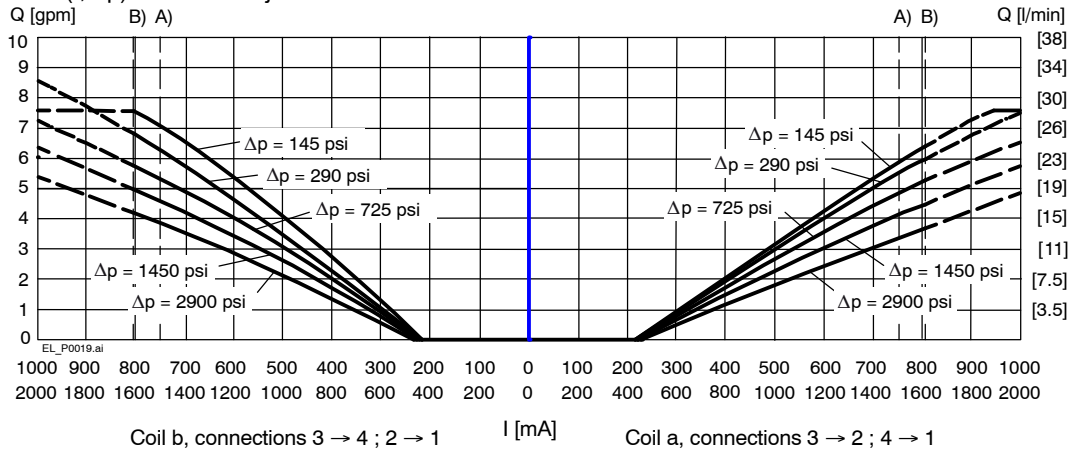

A) 100% duty cycle

B) 50% duty cycle

--- depending on coil temperature, solenoid may draw a voltage higher than the nominal voltage

Δp = f (Q) Pressure drop - Flow rate characteristic 4M

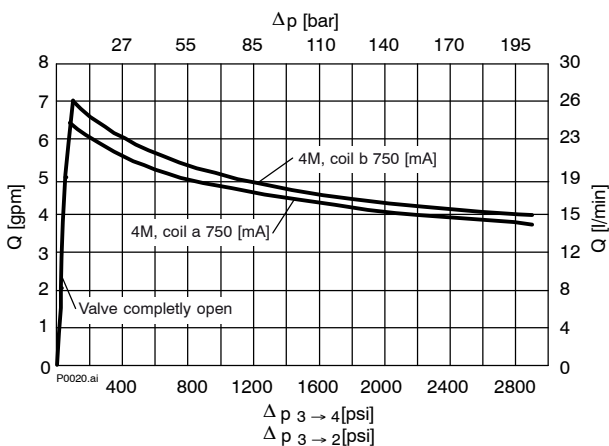

Δp = f (Q) Pressure drop - Flow rate characteristic 4L

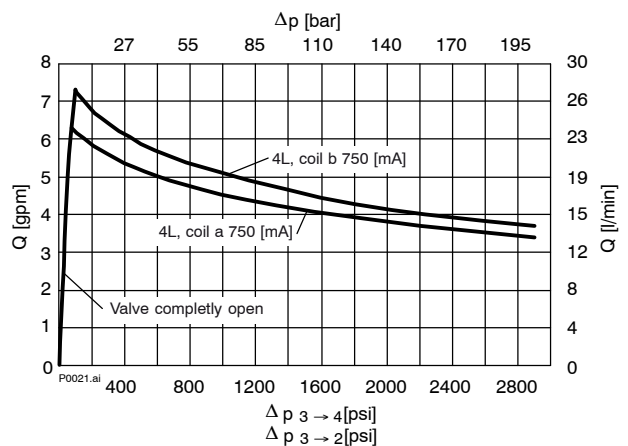

5 Dimensions & sectional view

4/3 proportional directional valve

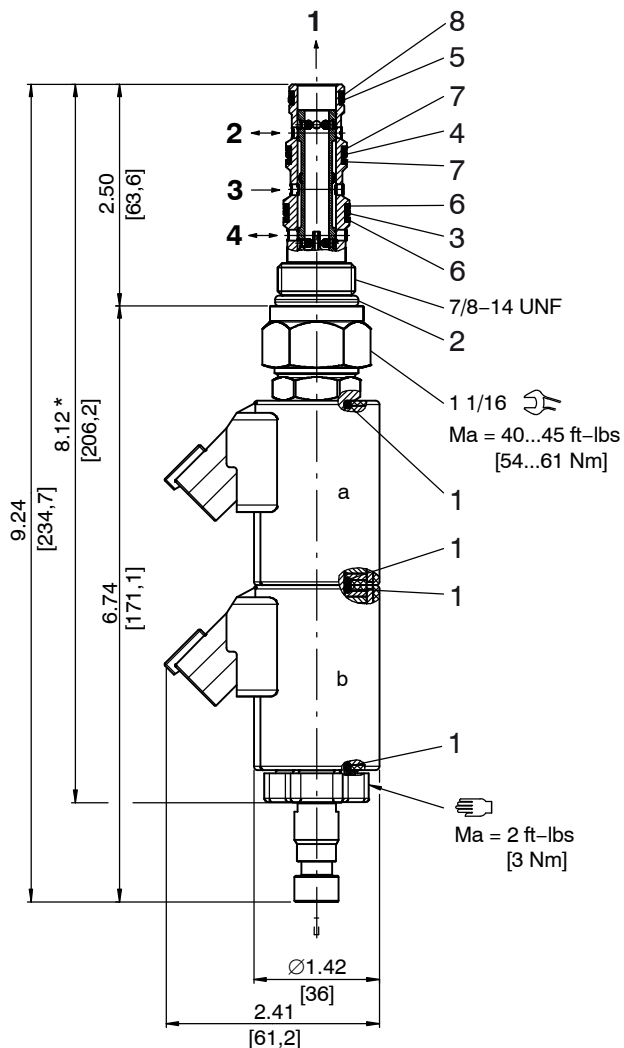

* overall length without manual over-ride

1. Push button to unlatch manual over-ride

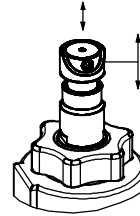

2. Push or pull on whole handle to shift valve to position a or b

Seal kit

Item	Qty.	Description
1	4	O-ring 16 x 2
2	1	O-ring no. 910 $\varnothing 0.755 \times 0.097$ [19,18 x 2,46]
3	1	O-ring no. 016 $\varnothing 0.614 \times 0.070$ [15,60 x 1,78]
4	1	O-ring no. 015 $\varnothing 0.551 \times 0.070$ [14,00 x 1,78]
5	1	O-ring no. 014 $\varnothing 0.489 \times 0.070$ [12,42 x 1,78]
6	2	Backup ring $\varnothing .634 \times .052 \times .047$ [16,10 x 1,32 x 1,19]
7	2	Backup ring $\varnothing .572 \times .052 \times .047$ [14,53 x 1,32 x 1,19]
8	1	Backup ring $\varnothing .510 \times .052 \times .047$ [12,95 x 1,32 x 1,19]



IMPORTANT!

Item no. 5207300112 = Seal kit NBR (Buna)
Item no. 5207300113 = Seal kit FKM (Viton)

6 Installation information



ATTENTION!

Only qualified personnel with mechanical skills may carry out any maintenance work. Generally, the only work that should ever be undertaken is to check, and possibly replace, the seals. When changing seals, oil or grease the new seals thoroughly before fitting them.



IMPORTANT!

When fitting the valves, use the specified tightening torque for the mounting bolts. No adjustments are necessary, since the cartridges are set in the factory.

7 Ordering code

	PDFC	-	10	-	N	-	4M	-	A	-	M	-	0	-	24	D	-
PDFC	= proportional directional valve																
10	= nominal size SAE 10																
N	= NBR (Nitrile) seals (standard)																
V	= FKM (Viton) seals (special seals - please consult BUCHER)																
4L	= cylinder spool, all ports closed in neutral																
4M	= motor spool, 2 and 4 connected to tank in neutral																
A	= factory set min current threshold at position b																
M	= with manual over-ride																
0	= without manual over-ride																
0	= cartridge only																
02BA	= line-mounting body G1/4 BSPP aluminum																
02BS	= line-mounting body G1/4 BSPP steel																
03BA	= line-mounting body G3/8 BSPP aluminum																
03BS	= line-mounting body G3/8 BSPP steel																
06TA	= line-mounting body SAE-#6 aluminum																
06TS	= line-mounting body SAE-#6 steel																
08TA	= line-mounting body SAE-#8 aluminum																
08TS	= line-mounting body SAE-#8 steel																
...	= voltage e.g. 24 (24 V)																
D	= current DC																
(blank)	= ISO 4400 / DIN 43 650 mating plug (standard, IP 65)																
M100	= without mating DIN plug																
C	= Kostal plug connection (IP 65)																
JT	= Junior Timer radial plug connection (with protection diode, IP65)																
IT	= Junior Timer axial plug connection (with protection diode, IP65)																
D	= Deutsch plug connection DT04-2P (IP 67/69K)																
DT	= Deutsch plug connection DT04-2P (with protection diode, IP 67/69K)																
S	= AMP Superseal 1.5 (IP 67) / Metri-Pack 150 (IP 65)																
F	= flying leads (500 mm)																
	} mating plug not supplied																

8 Related data sheets

Reference	(Old no.)	Description
520-P-000050		The form-tool hire programme
520-P-000420	(0-042.0)	Cavity Type C1040
520-P-000421	(0-042.1)	Line-mounting body, 10 Series – 4-way

info.el@bucherhydraulics.com

www.bucherhydraulics.com/commoncavity

© 2015 by Bucher Hydraulics, Inc., 2545 Northwest Parkway, Elgin, Illinois 60124, USA

All rights reserved.

Data is provided for the purpose of product description only, and must not be construed as warranted characteristics in the legal sense. The information does not relieve users from the duty of conducting their own evaluations and tests. Because the products are subject to continual improvement, we reserve the right to amend the product specifications contained in this catalogue.

Classification: 430.300.-.305.310.310.300.300

PROPORTIONAL PRESSURE REDUCING/
RELIEVING. DIRECT ACTING, SPOOL TYPE.

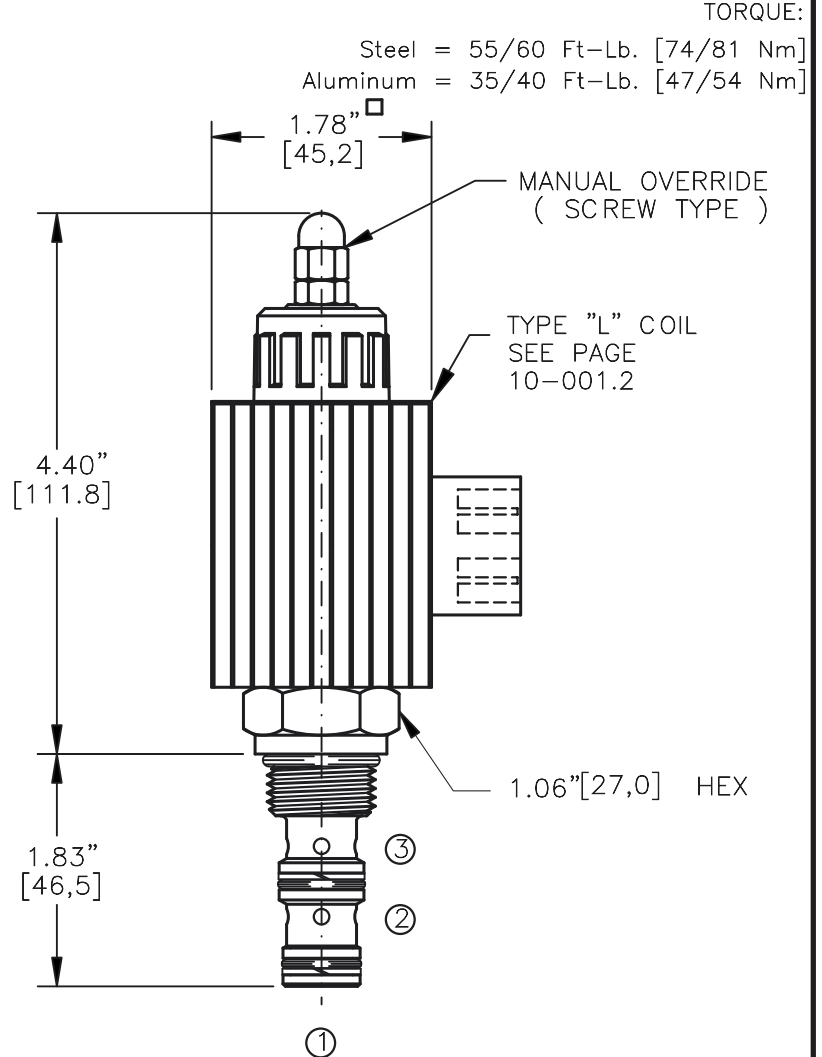
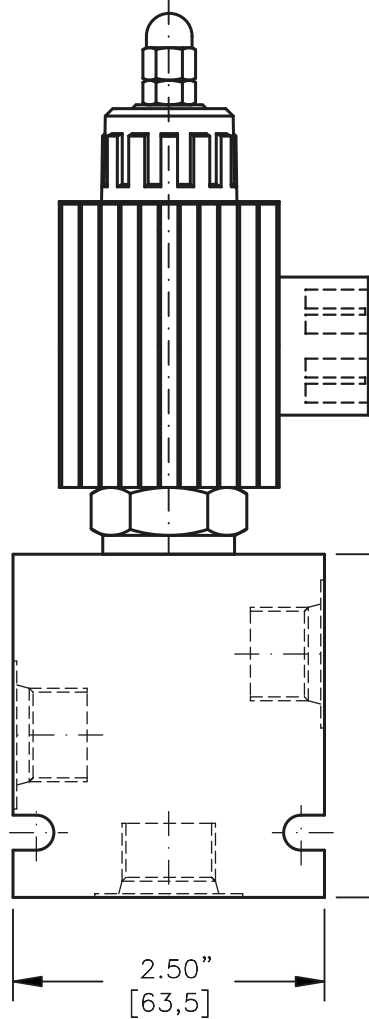
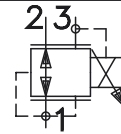

TORQUE:

Steel = 55/60 Ft-Lb. [74/81 Nm]
Aluminum = 35/40 Ft-Lb. [47/54 Nm]

NOTES:

1. FOR ALUMINUM OR STEEL VALVE HOUSING CONFIGURATIONS SEE PAGE 0-032.1
2. SOLENOIDS AVAILABLE WITH DIODES - CONSULT FACTORY.

EPRR-10-X-XX-X-X-XXX X

BASIC	TERMINALS
SIZE	L = 18GA. 24" LEADS
10 = 7/8"-14UNF	T = SPADE TERM.
SEALS	B = BOLT TERM.
N = BUNA "N"	G = DIN43650
V = VITON	W = WEATHER-PACK
REGULATED PRESSURE	D = DEUTSCH-DT04-2P
02 = 0 TO 200 PSI	M = METRI-PACK CONN.
03 = 0 TO 300 PSI	VOLTAGE AMPS
04 = 0 TO 400 PSI	12D = 12 VDC 3.00
05 = 0 TO 500 PSI	24D = 24 VDC 1.50
06 = 0 TO 600 PSI	ADJUSTMENT OPTIONS
07 = 0 TO 700 PSI	M = MANUAL OVERRIDE
08 = 0 TO 800 PSI	PORTS = CARTRIDGE ONLY
10 = 0 TO 1000 PSI	0 = G 1/4" BSPP
	02BX = G 3/8" BSPP
	03BX = SAE - #6
	06TX = SAE - #8
	08TX "A" = ALUM. HOUSING
	"S" = STEEL HOUSING

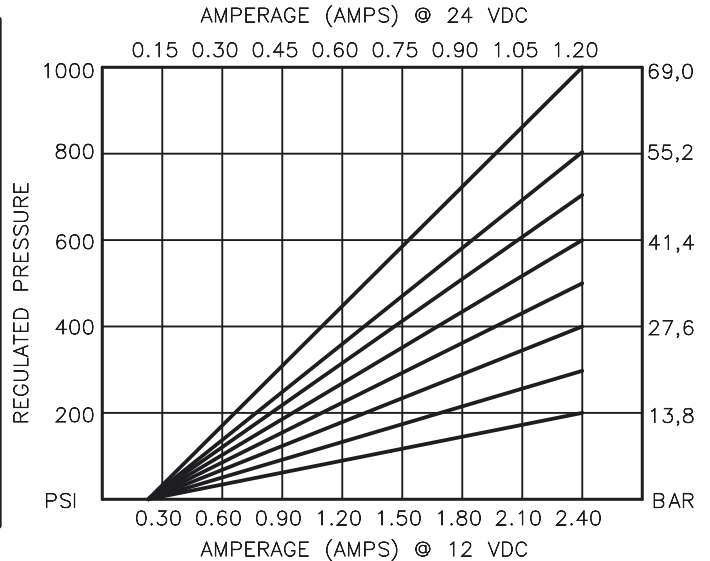

ELECTRO-HYDRAULIC, PROPORTIONAL, PRESSURE REDUCING/RELIEVING VALVE.

DESCRIPTION

This unit is a electro-hydraulic, proportional, screw in cartridge style, direct acting, spool type, pressure reducing/relieving flow pressure control valve.

OPERATIONS

When the coil is de-energized, this valve allows no flow or pressure from port 2 to 1 and port 1 is open to (tank) port 3.

When the coil is energized, the spool in this valve shifts and allows flow and pressure between ports 2 and 1 and blocks port 3 (tank).

When the coil is energized the armature moves a precision bias spring against the metering spool thus varying the pressure at port 1 (Reg.) proportional to the current input. When the current is increased to the coil the pressure will increase and when decreased it will decrease.

IN THE EVENT OF POWER FAILURE THE VALVE WILL REDUCE REGULATED PRESSURE AT PORT 1 TO ZERO.

FEATURES AND BENEFITS

Continuous-duty, very low heat rise & waterproof solenoid coil.

Interchangeable solenoid coils & terminations options available.

Hardened precision fitted spool & sleeve provides reliable, long life.

Very efficient wet - armature solenoid core tube construction.

All external carbon steel parts are plated for longer life against the elements.

All cartridge valves are 100% functionally tested.

Industry common cavity.

**ELECTRO-HYDRAULIC, PROPORTIONAL,
PRESSURE REDUCING/RELIEVING VALVE.****SPECIFICATIONS**

OPERATING PRESSURE: 5,000 PSI [350 Bar]

PROOF PRESSURE: 10,000 PSI [700 Bar]

REGULATED PRESSURE: 0 to 1,000 PSI [0 to 69,0 Bar] See performance chart

FLOW: 1.0 GPM (3.8 l/m) nominal

INTERNAL LEAKAGE: 10 cu.in/min [164 cc/m] @ 5,000 PSI [350 Bar]

VALVE HOUSINGS: 2500 PSI [175 Bar] = Aluminum - Anodized.

5000 PSI [350 Bar] = Steel - Unplated.

OPERATING TEMPERATURE: -40° to +250° F. [-40° to +120° C.]

OPERATING MEDIA: All general purpose hydraulic fluids such as
MIL-H-5606, SAE-#10, SAE-#20, etc.

RESPONSE: The most efficient method to control this valve is with
current control and a 50 Hz dither.

POWER REQUIREMENTS: 12 VDC, Operating current 0.2 to 2.4 AMPS.

24 VDC, Operating current 0.1 to 1.2 AMPS.

SEAL KIT: SKN-1031 Buna "N"

SKV-1031 Viton

INSTALLATION: No restrictions.

WEIGHT: 1.95 lb [.88 kg] cartridge with coil only.

VALVE CAVITY: #C1030, See Page 0-032.0.

info.el@bucherhydraulics.com

www.bucherhydraulics.com/commoncavity

© 2015 by Bucher Hydraulics, Inc., 2545 Northwest Parkway, Elgin, Illinois 60124, USA

All rights reserved.

The technical information in this catalog, may contain calculated figures (for reference only) and not actual performance data for this product.

Data is provided for the purpose of product description only, and must not be construed as warranted characteristics in the legal sense.

The information does not relieve users from the duty of conducting their own evaluations and tests. Because the products are subject to continual improvement, we reserve the right to amend the product specifications contained in this catalogue.

Prop. Pressure-Reducing/Relieving Cartridge, Size SAE 08

$Q_{\max} = 7.0 \text{ gpm [26 l/min]}$, $p_{\max} = 3400 \text{ psi [240 bar]}$
Seated pilot, spool-type main stage
Series EPRT-08...



- Compact construction for cavity types:
C0830 - 3/4-16 UNF
- Operated by a proportional solenoid
- 3 pressure ranges available
- Full-flow secondary pressure relief
- Internal pilot-oil drain
- Pilot stage protected from dirt by gap filter
- Excellent stability over the whole pressure and flow range
- All exposed parts with zinc-nickel plating
- High pressure wet-armature solenoids
- The slip-on coil can be rotated, and it can be replaced without opening the hydraulic envelope
- Various plug-connector systems and voltages are available
- Can be fitted in a line-mounting body

1 Description

Series EPRT-08... proportional pressure-reducing / relieving valves are size SAE 08, high performance screw-in cartridges with a 3/4-16 UNF mounting thread. Using the leak-free seat-type pilot cartridge, the secondary pressure in port 1 is dependent on the electrical control signal and it can be continuously varied and set at any desired level. In control mode, the connection 2 → 1 opens until the pressure in port 1 reaches the preset level. If the pressure rises above the preset level, the control spool opens the 1 → 3 connection until balance is attained. These pressure-reducing / relieving cartridges function as full-flow pressure relief valves from port 1 → 3 as soon as the reduced pressure rises above the valve pressure setting. A high degree of func-

tional stability is reached even if the back pressure in the tank line fluctuates. Three pressure ranges are available in order to obtain precise pressure settings over the whole pressure range. These pressure-reducing / relieving cartridges are predominantly used in mobile and industrial applications for reducing a system pressure. All external parts of the cartridge are zinc-nickel plated according to DIN EN ISO 19 598 and are thus suitable for use in the harshest operating environments. The slip-on coils can be replaced without opening the hydraulic envelope and can be positioned at any angle through 360°. For self-assembly, please refer to the section related data sheets.

2 Symbol

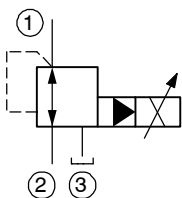

3 Technical data

General characteristics	Description, value, unit
Designation	proportional pressure-reducing / relieving cartridge
Design	seated pilot, spool-type main stage
Mounting method	screw-in cartridge 3/4-16 UNF-2A
Tightening torque	30 ft-lbs ± 10 % [40 Nm ± 10 %]

Reference: 520-P-110260-EN-02

General characteristics	Description, value, unit	
Size	size SAE 08 for cavity type C0830 fits common cavity ISO 17209: 3/4-03-0-13 fits common cavity NFPA/T3.5.50: 0.750-03-0-09	
Weight	0.93 lbs	[0.42 kg]
Mounting attitude	unrestricted (preferably vertical, coil down)	
Ambient temperature range	-13 °F ... +122 °F	[-25 °C ... +50 °C]

Hydraulic characteristics	Description, value, unit	
Maximum operating pressure - ports 1, 2 - port 3	3400 psi 3000 psi	[240 bar] [210 bar] ¹⁾
Maximum flow rate	7 gpm	[26 l/min]
Nominal pressure ranges	1500, 2500, 3000 psi	[100, 175, 210 bar] <small>For further pressure ranges, please contact BUCHER</small>
Pilot-oil consumption	0.05... 0.08 gpm	[0,2 ... 0,3 l/min]
Flow direction	2 → 1 pressure reducing 1 → 3 pressure relieving	
Hydraulic fluid	HL and HLP mineral oil to DIN 51 524; for other fluids, please contact BUCHER	
Hydraulic fluid temperature range	-13 °F ... +158 °F	[-25 °C ... +70 °C]
Viscosity range	15...380 mm ² /s (cSt), recommended 20...130 mm ² /s (cSt)	
Minimum fluid cleanliness Cleanliness class to ISO 4406 : 1999	class 18/16/13	



ATTENTION!

¹⁾ To prevent any pressure surges, port 3 must be routed to tank with the least possible back-pressure.

Electrical characteristics	Description, value, unit	
Supply voltage	12 V DC, 24 V DC	
Supply voltage tolerance	± 10 %	
Control current	12 V = 0... 1400 mA, 24 V = 0... 750 mA	
Power consumption at max. control current	max. 19 W	
Coil resistance R - cold value at 20 °C - max. warm value	12 V = 5.8 Ω / 24 V = 21 Ω 12 V = 8.6 Ω / 24 V = 32 Ω	
Recommended PWM frequency (dither)	200 Hz	
Hysteresis with PWM	2...4 % I _N	
Reversal error with PWM	1...3 % I _N	
Sensitivity with PWM	≤ 1 % I _N	
Reproducibility with PWM	< 2 % p _N	

Electrical characteristics	Description, value, unit
Switching time	<i>Pressure-reducing function:</i> 38 ... 45 ms (solenoid ON) 8 ... 12 ms (solenoid OFF) <i>Pressure-relief function:</i> 41 ... 51 ms (solenoid ON) 6 ... 12 ms (solenoid OFF) The switching times are strongly influenced by flow rate, pressure, viscosity and the dwell period under pressure.
Relative duty cycle	100 %
Protection class to ISO 20 653 / EN 60 529	IP 65 / IP 67 / IP 69K, see "Ordering code" (with appropriate mating connector and proper fitting and sealing)
Electrical connection	DIN EN 175301-803, 3-pin 2 P+E (standard) for other connectors, see "Ordering code"

4 Performance graphs measured with oil viscosity 33 mm²/s (cSt)

$p = f(I)$ Pressure adjustment characteristic

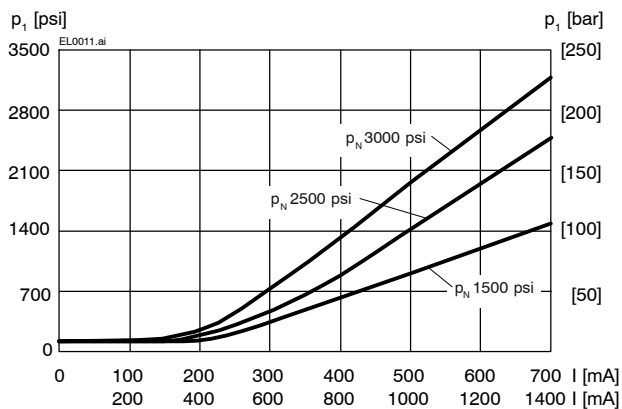

$\rho = f(Q)$ Pressure - Flow rate characteristic [$\rho_N = 3000 \text{ psi}$]

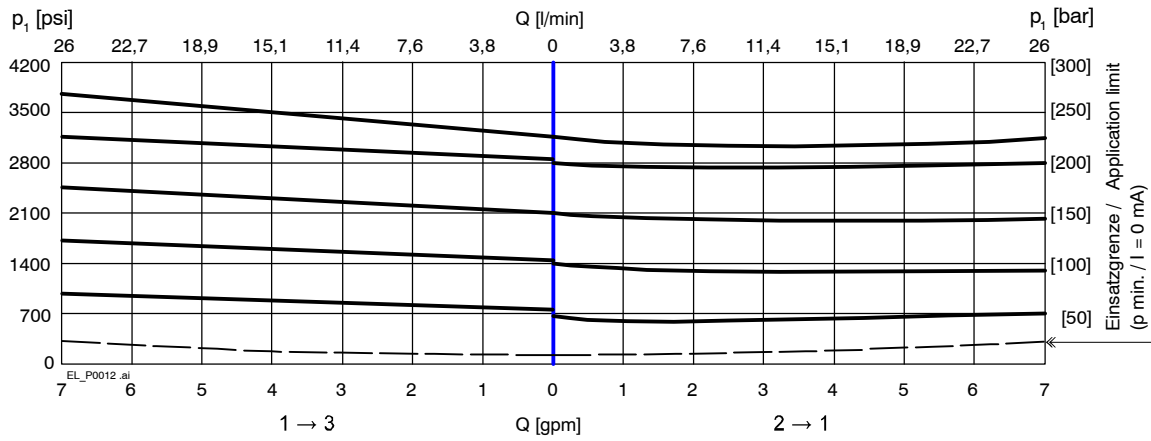

$\rho = f(Q)$ Pressure - Flow rate characteristic [$\rho_N = 2500 \text{ psi}$]

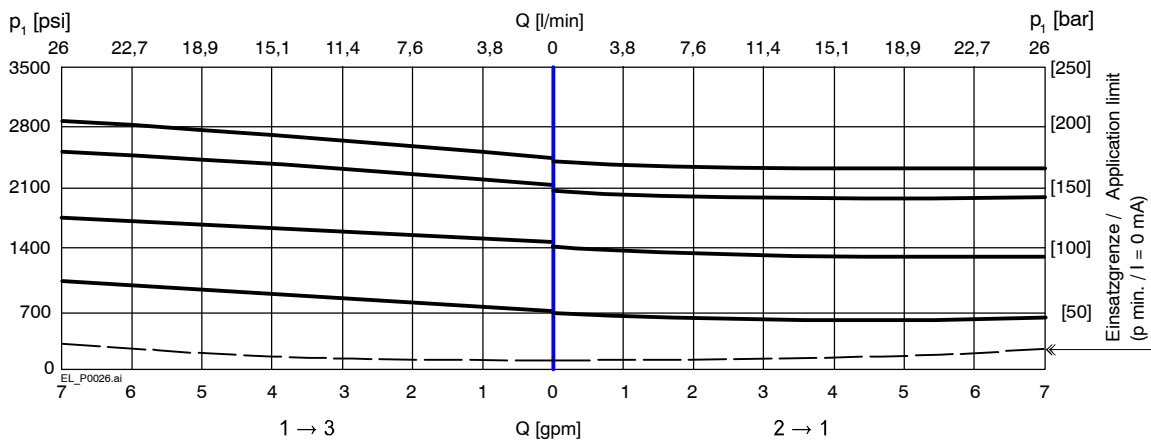

$\rho = f(Q)$ Pressure - Flow rate characteristic [$\rho_N = 1500 \text{ psi}$]

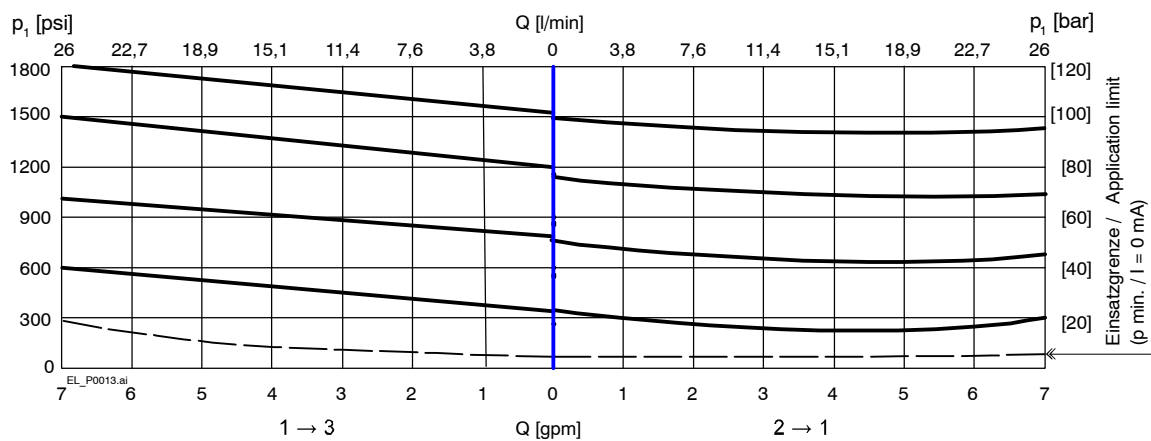

5 Dimensions & sectional view

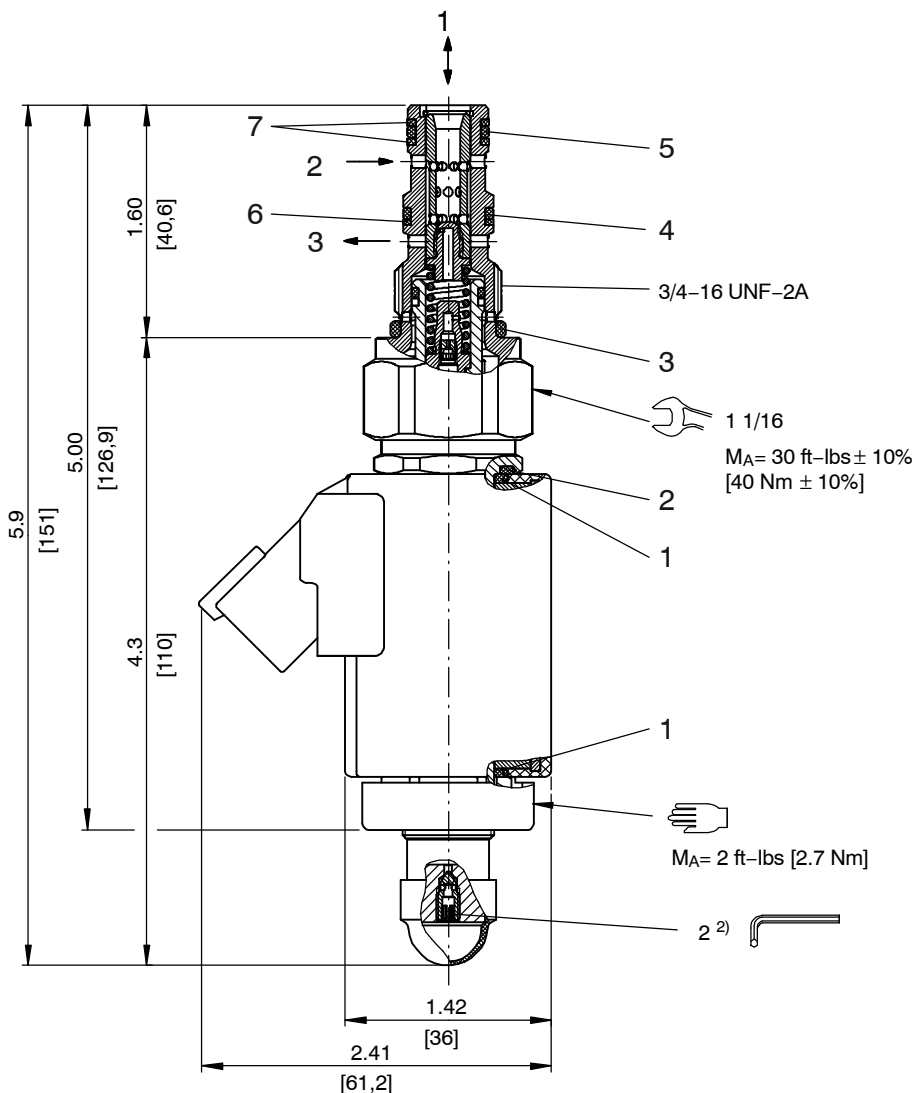

6 Installation information



IMPORTANT!

To achieve the proportional pressure-reducing cartridge's maximum performance rating, fit the solenoid coil as shown (with the plug pins at the bottom). When fitting the cartridges, note the mounting attitude (preferably vertical, with coil down → automatic air bleed) and use the specified tightening torque. No adjustments are necessary, since the cartridges are set in the factory.



ATTENTION!

Only qualified personnel with mechanical skills may carry out any maintenance work. Generally, the only work that should ever be undertaken is to check, and possibly replace, the seals. When changing seals, oil or grease the new seals thoroughly before fitting them.

Seal kit NBR no. SKN-0832-12-S1 ¹⁾

Item	Qty.	Description			
1	2	O-ring	∅ 16,00 x 2,00	FKM	mm
2	1	O-ring	∅ 18,00 x 2,00	FKM	mm
3	1	O-ring no. 908	∅ 0,644 x 0,087	N70	Inch
4	1	O-ring no. 014	∅ 0,489 x 0,070	N70	Inch
5	2	O-ring no. 013	∅ 0,426 x 0,070	N70	Inch
6	1	Backup ring FI0751	∅ 0,421 x 0,057 x 0,039		Inch
7	2	Backup ring FI0751	∅ 0,370 x 0,057 x 0,039		Inch



IMPORTANT!

- 1) Seal kit with FKM (Viton) seals, no. SKV-0832-12-S1
- 2) vent screw to vent valve when mounted coil up screw torqued hand tight.

7 Ordering code

Ex. **EPRT** - **08** - **N** - **30** - **0** - **24** **D** **_**

EPRT	=	prop. pressure-reducing / relieving valve, two stage	
08	=	nominal size SAE 08	
N	=	NBR (Nitrile) seals (standard)	
V	=	FKM (Viton) seals (special seals - please contact BUCHER)	
30	=	Pressure option 3000 psi	
25	=	Pressure option 2500 psi	
15	=	Pressure option 1500 psi	
0	=	cartridge only	
02BA	=	line-mounting body G1/4 BSPP	aluminum
02BS	=	line-mounting body G1/4 BSPP	steel
03BA	=	line-mounting body G3/8 BSPP	aluminum
03BS	=	line-mounting body G3/8 BSPP	steel
06TA	=	line-mounting body SAE-6	aluminum
06TS	=	line-mounting body SAE-6	steel
...	=	voltage e.g. 24 (24 V)	
D	=	current DC	
(blank)	=	DIN EN 175301-803 connection with mating plug (standard, IP 65)	
M100	=	DIN EN 175301-803 connection without mating plug	
C	=	Kostal plug connection (IP 65)	} mating plug not supplied
JT	=	Junior Timer radial plug connection (with protection diode, IP65)	
IT	=	Junior Timer axial plug connection (with protection diode, IP65)	
D	=	Deutsch plug connection 45° DT04-2P (IP67/69K)	
DT	=	Deutsch plug connection 45° DT04-2P (with protection diode, IP67/69K)	
S	=	AMP Superseal 1.5 (IP67) / Metri-Pack 150 (IP65) plug connection	
F	=	flying leads (500 mm)	

} on request

8 Related data sheets

Reference	(Old no.)	Description
520-P-000050		The form-tool loan program
520-P-000310	(0-031.0)	Cavity type C0830
400-P-120110	(W-2.141)	Coils for screw-in cartridge valves
520-P-000311	(0-031.1)	Line-mounting body, 8 Series -3-way

info.el@bucherhydraulics.com

www.bucherhydraulics.com/commoncavity

© 2021 by Bucher Hydraulics, Inc., 2545 Northwest Parkway, Elgin, Illinois 60124, USA

All rights reserved.

Data is provided for the purpose of product description only, and must not be construed as warranted characteristics in the legal sense. The information does not relieve users from the duty of conducting their own evaluations and tests. Because the products are subject to continual improvement, we reserve the right to amend the product specifications contained in this catalogue.

Classification: 430.300.305.305.320.310

PROPORTIONAL PRESSURE REDUCING/
RELIEVING. PILOT OPERATED, SLIDING SPOOL

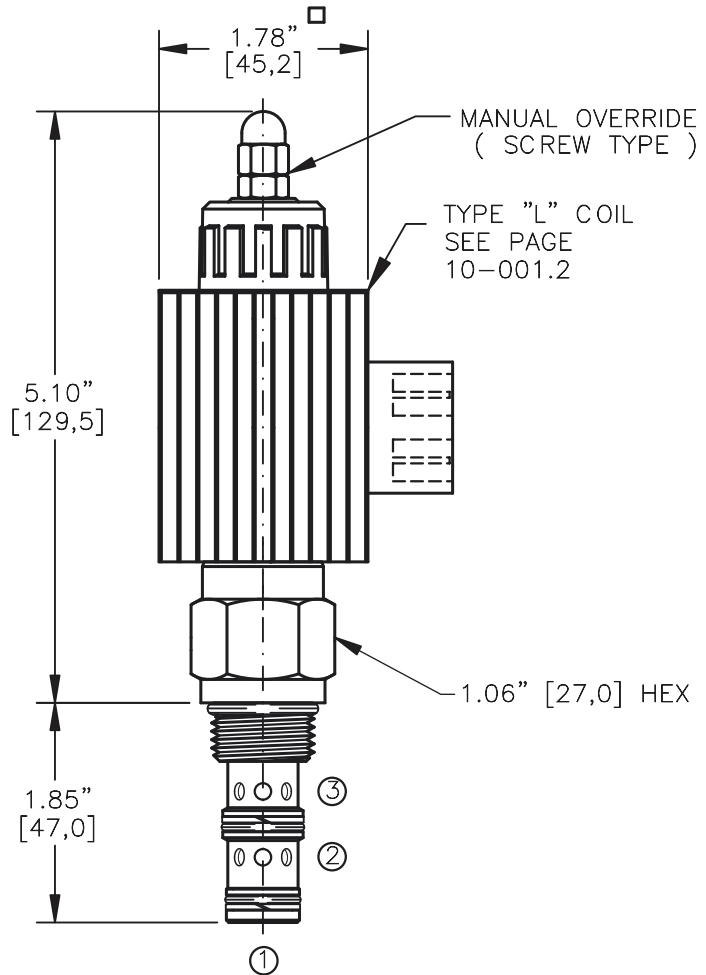
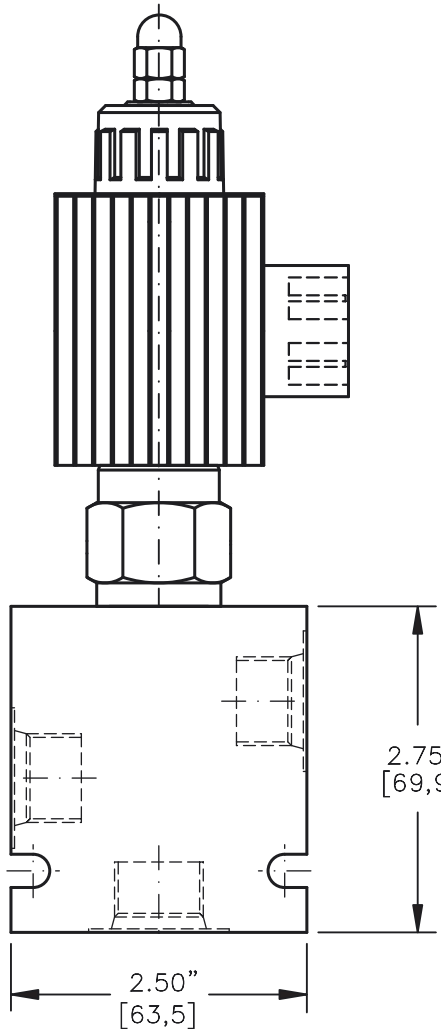
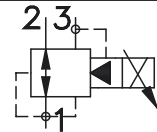

TORQUE:

Steel = 55/60 Ft-Lb. [74/81 Nm]
Aluminum = 35/40 Ft-Lb. [47/54 Nm]

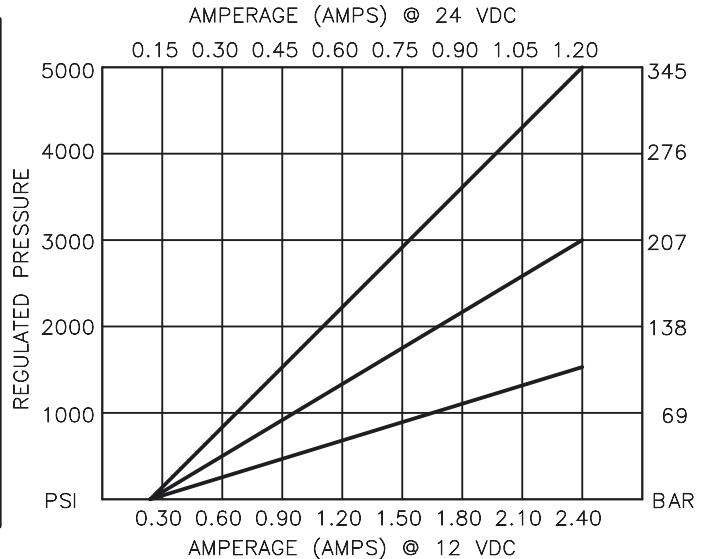
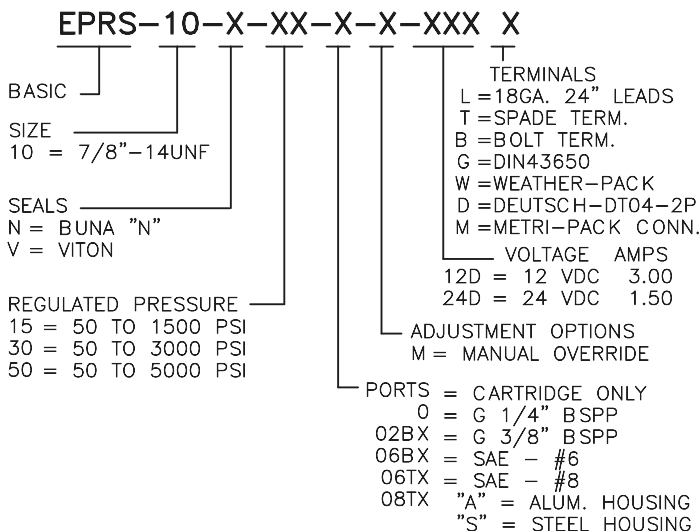

ELECTRO-HYDRAULIC, PROPORTIONAL, PRESSURE REDUCING/RELIEVING VALVE.

DESCRIPTION

This unit is a electro-hydraulic, proportional, screw in cartridge style, pilot operated, sliding spool type, high pressure reducing and relieving control valve.

OPERATIONS

When the coil is de-energized, this valve will allow flow from port 2 to port 1 until pressure in port 1 exceeds the spring bias then the spool will shift and block flow from port 2 to port 1 relieving pressure to port 3. When the coil is energized, the armature moves a precision bias spring against the pilot orifice thus varying the pressure at port 1 (reg.) proportional to the current input regardless of the pressure at port 2. Excess pressure at port 1 is relieved to port 3. When the coil current is increased the pressure will increase and when decreased it will decrease. IN THE EVENT OF POWER FAILURE THE VALVE WILL REDUCE REGULATED PRESSURE AT PORT 1 TO 50 PSI.

FEATURES AND BENEFITS

Continuous-duty, very low heat rise & waterproof solenoid coil.

Pressure in tank port (3) will add to the bias spring setting, and is limited to 2000 PSI.

Interchangeable solenoid coils & terminations options available.

Hardened precision fitted spool & sleeve provides reliable, long life.

A unique self aligning (floating) cage provides very low hysteresis and reliable operation.

Very efficient wet – armature solenoid core tube construction.

All external carbon steel parts are plated for longer life against the elements.

All cartridge valves are 100% functionally tested.

Industry common cavity.

**ELECTRO-HYDRAULIC, PROPORTIONAL,
PRESSURE REDUCING/RELIEVING VALVE.****SPECIFICATIONS**

OPERATING PRESSURE: 5,000 PSI [350 Bar]

PROOF PRESSURE: 10,000 PSI [700 Bar]

REGULATED PRESSURE: 50 to 5000 PSI [3,5 to 345] See performance chart.

FLOW: 12.0 GPM [46,0 L/M] nominal.

INTERNAL PILOT FLOW: 20 cu.in/min [0,50 l/m] @ 5,000 PSI [350 Bar]

VALVE HOUSINGS: 2500 PSI [175 Bar] = Aluminum – Anodized.

5000 PSI [350 Bar] = Steel – Unplated.

OPERATING TEMPERATURE: -40° to +250° F. [-40° to +120° C.]

OPERATING MEDIA: All general purpose hydraulic fluids such as
MIL-H-5606, SAE-#10, SAE-#20, etc.

RESPONSE: The most efficient method to control this valve is with
current control and a 50 Hz dither.

POWER REQUIREMENTS: 12 VDC, Operating current 0.2 to 2.4 AMPS.

24 VDC, Operating current 0.1 to 1.2 AMPS.

SEAL KIT: SKN-1031 Buna "N"

SKV-1031 Viton

INSTALLATION: No restrictions.

WEIGHT: 1.95 lb [.88 kg] cartridge with coil only.

VALVE CAVITY: #C1030, See Page 0-032.0.

info.el@bucherhydraulics.com

www.bucherhydraulics.com/commoncavity

© 2015 by Bucher Hydraulics, Inc., 2545 Northwest Parkway, Elgin, Illinois 60124, USA

All rights reserved.

The technical information in this catalog, may contain calculated figures (for reference only) and not actual performance data for this product.

Data is provided for the purpose of product description only, and must not be construed as warranted characteristics in the legal sense.

The information does not relieve users from the duty of conducting their own evaluations and tests. Because the products are subject to continual improvement, we reserve the right to amend the product specifications contained in this catalogue.

PROPORTIONAL PRESSURE REDUCING/
RELIEVING PILOT OPERATED, SLIDING SPOOL

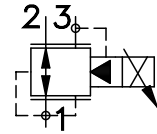

TORQUE:

Steel = 70/75 Ft-Lb. [95/102 Nm]
Aluminum = 55/60 Ft-Lb. [74/81 Nm]

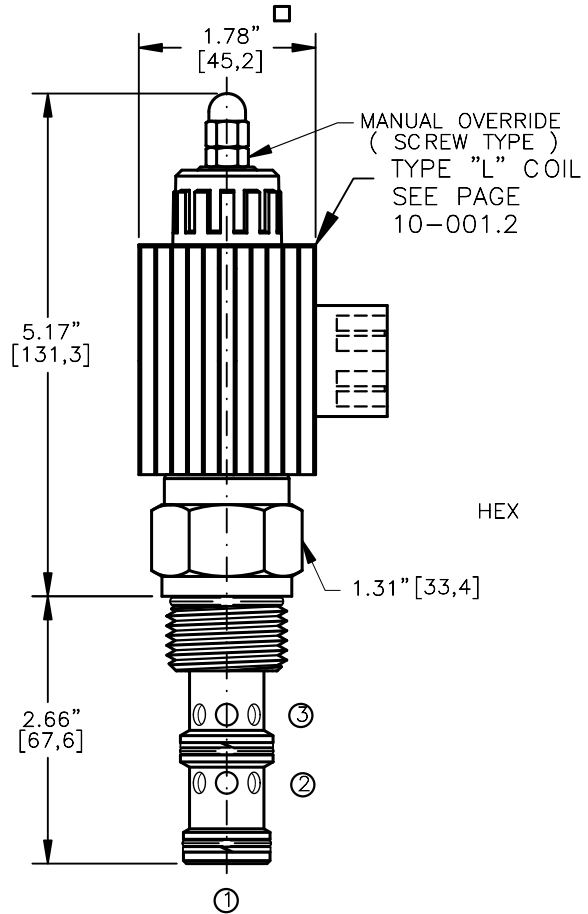
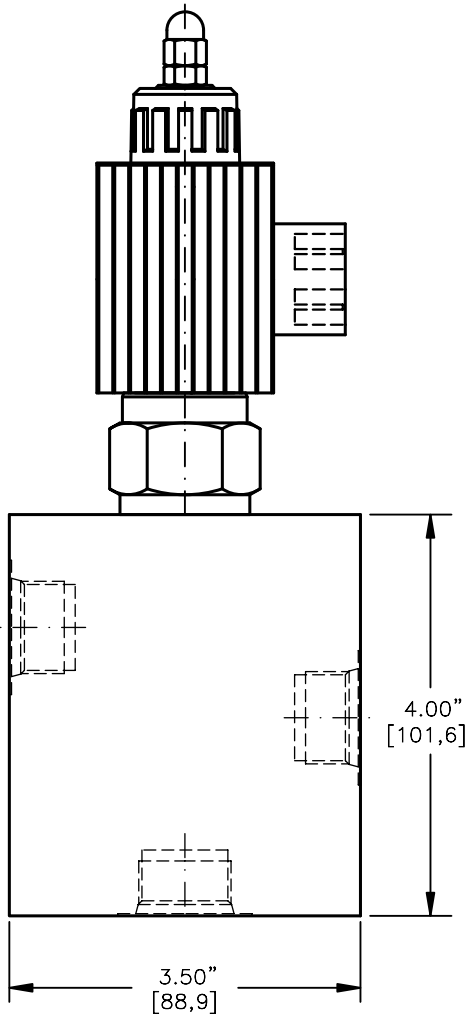

NOTES:

1. FOR ALUMINUM OR STEEL VALVE HOUSING CONFIGURATIONS SEE PAGE 0-033.1
2. SOLENOIDS AVAILABLE WITH DIODES - CONSULT FACTORY.

EPRS-12-X-XX-X-X-XXX X

BASIC

SIZE

12 = 1.062"-12UNF

SEALS

N = BUNA "N"
V = VITON

REGULATED PRESSURE

15 = 50 TO 1500 PSI
30 = 50 TO 3000 PSI
50 = 50 TO 5000 PSI

TERMINALS

L = 18GA. 24" LEADS
T = SPADE TERM.
B = BOLT TERM.
G = DIN43650
W = WEATHER-PACK
D = DEUTSCH-DT04-2P
M = METRI-PACK CONN.

VOLTAGE AMPS
12D = 12 VDC 3.00
24D = 24 VDC 1.50

ADJUSTMENT OPTIONS
M = MANUAL OVERRIDE

PORTS

0 = CARTRIDGE
4BX = G 1/2" BSPP
6BX = G 3/4" BSPP
10TX = SAE - #10
12TX = SAE - #12
"A" - ALUM. HOUSING
"S" - STEEL HOUSING

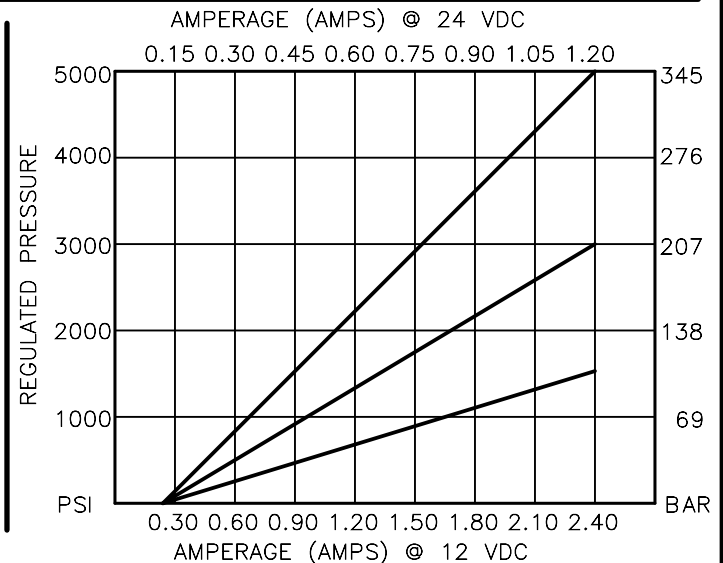

ELECTRO-HYDRAULIC, PROPORTIONAL, PRESSURE REDUCING/RELIEVING VALVE.

DESCRIPTION

This unit is a electro-hydraulic, proportional, screw in cartridge style, pilot operated, sliding spool type, high pressure reducing and relieving control valve.

OPERATIONS

When the coil is de-energized, this valve will allow flow from port 2 to port 1 until pressure in port 1 exceeds the spring bias then the spool will shift and block flow from port 2 to port 1 relieving pressure to port 3. When the coil is energized, the armature moves a precision bias spring against the pilot orifice thus varying the pressure at port 1 (reg.) proportional to the current input regardless of the pressure at port 2. Excess pressure at port 1 is relieved to port 3. When the coil current is increased the pressure will increase and when decreased it will decrease. IN THE EVENT OF POWER FAILURE THE VALVE WILL REDUCE REGULATED PRESSURE AT PORT 1 TO 50 PSI.

FEATURES AND BENEFITS

Continuous-duty, very low heat rise & waterproof solenoid coil.
Pressure in tank port (3) will add to the bias spring setting, and is limited to 2000 PSI.
Interchangeable solenoid coils & terminations options available.
Hardened precision fitted spool & sleeve provides reliable, long life.
A unique self aligning (floating) cage provides very low hysteresis and reliable operation.
Very efficient wet-armature solenoid core tube construction.
All external carbon steel parts are plated for longer life against the elements.
All cartridge valves are 100% functionally tested.

**ELECTRO-HYDRAULIC, PROPORTIONAL,
PRESSURE REDUCING/RELIEVING VALVE.****SPECIFICATIONS**

OPERATING PRESSURE: 5,000 PSI [350 Bar]

PROOF PRESSURE: 10,000 PSI [700 Bar]

REGULATED PRESSURE: 50 to 5000 PSI [3,5 to 345] See performance chart.

FLOW: 24.0 GPM [91,0 L/M] nominal.

INTERNAL PILOT FLOW: 60 cu.in./min [1,0 l/m] @ 5,000 PSI [350 Bar]

VALVE HOUSINGS: 2500 PSI [175 Bar] = Aluminum - Anodized.

5000 PSI [350 Bar] = Steel - Unplated.

OPERATING TEMPERATURE: -40° to +250° F. [-40° to +120° C.]

OPERATING MEDIA: All general purpose hydraulic fluids such as
MIL-H-5606, SAE-#10, SAE-#20, etc.

RESPONSE: The most efficient method to control this valve is with
current control and a 50 Hz dither.

POWER REQUIREMENTS: 12 VDC, Operating current 0.2 to 2.4 AMPS.

24 VDC, Operating current 0.1 to 1.2 AMPS.

SEAL KIT: SKN-1231 Buna "N"

SKV-1231 Viton

INSTALLATION: No restrictions.

WEIGHT: 2.3 lb [1,2 kg] cartridge with coil only.

VALVE CAVITY: #C1230, See Page 0-033.0.

info.el@bucherhydraulics.com

www.bucherhydraulics.com/commoncavity

© 2015 by Bucher Hydraulics, Inc., 2545 Northwest Parkway, Elgin, Illinois 60124, USA

All rights reserved.

The technical information in this catalog, may contain calculated figures (for reference only) and not actual performance data for this product.

Data is provided for the purpose of product description only, and must not be construed as warranted characteristics in the legal sense.

The information does not relieve users from the duty of conducting their own evaluations and tests. Because the products are subject to continual improvement, we reserve the right to amend the product specifications contained in this catalogue.

PROPORTIONAL PRESSURE RELIEF VALVE.
PILOT OPERATED, SLIDING SPOOL TYPE.

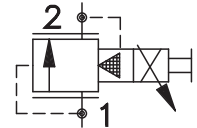

Pat.#5,546,980

TORQUE:

Steel = 55/60 Ft-Lb. [74/81 Nm]
Aluminum = 35/40 Ft-Lb. [47/54 Nm]

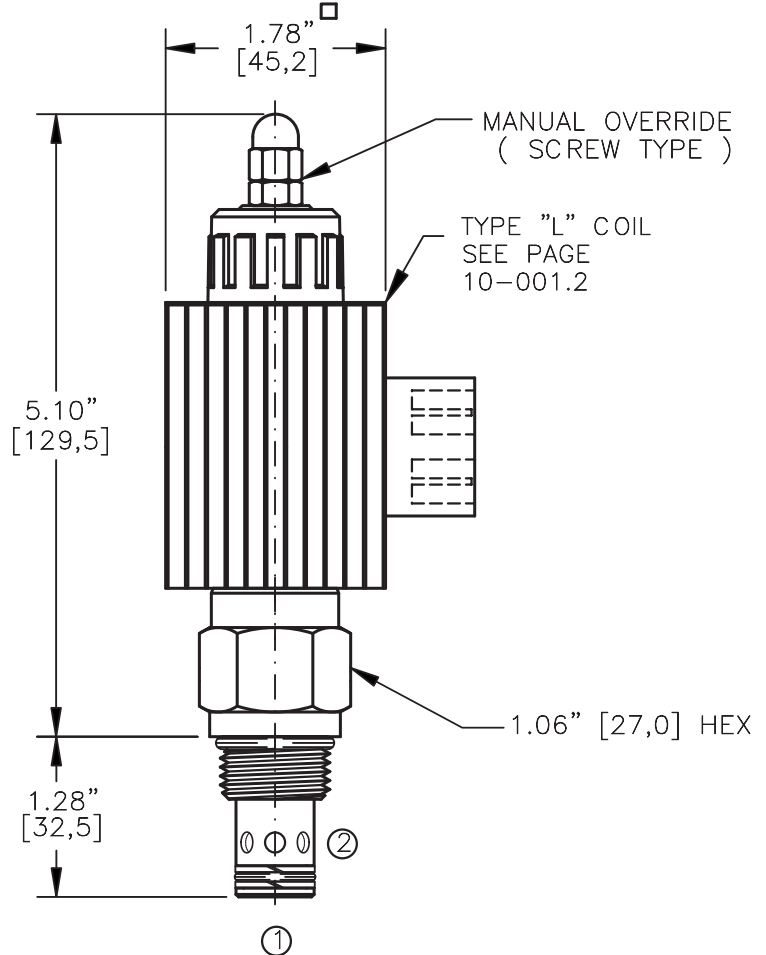
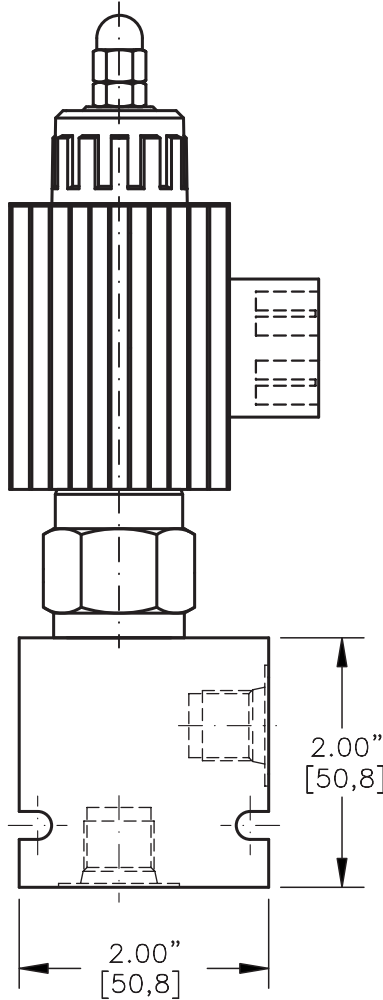

NOTES:

1. FOR ALUMINUM OR STEEL VALVE HOUSING CONFIGURATIONS SEE PAGE 0-012.1
2. SOLENOIDS AVAILABLE WITH DIODES - CONSULT FACTORY.

ERVP-10-X-XX-X-X-XXX X

BASIC

SIZE

10 = 7/8"-14UNF

SEALS

N = BUNA "N"

V = VITON

REGULATED PRESSURE

15 = 50 TO 1500 PSI

30 = 50 TO 3000 PSI

50 = 50 TO 5000 PSI

TERMINALS

L = 18GA. 24" LEADS

T = SPADE TERM.

B = BOLT TERM.

G = DIN43650

W = WEATHER-PACK

D = DEUTSCH-DT04-2P

M = METRI-PACK CONN.

VOLTAGE AMPS

12D = 12 VDC 3.00

24D = 24 VDC 1.50

ADJUSTMENT OPTIONS

M = MANUAL OVERRIDE

PORTS = CARTRIDGE ONLY

0 = G 1/4" BSPP

02BX = G 3/8" BSPP

06BX = SAE - #6

06TX = SAE - #8

08TX "A" = ALUM. HOUSING

"S" = STEEL HOUSING

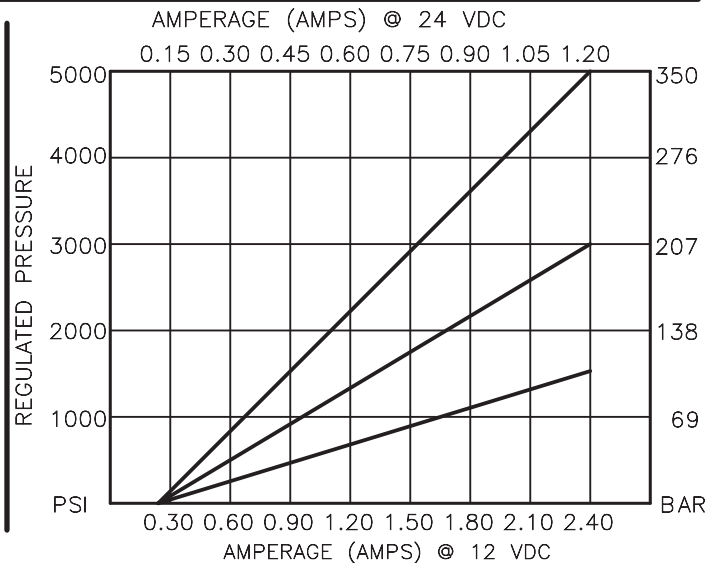

ELECTRO–HYDRAULIC, PROPORTIONAL, PRESSURE RELIEF VALVE.

DESCRIPTION

This unit is a electro–hydraulic, proportional, screw in cartridge style, pilot operated, sliding spool type, high pressure relief valve.

OPERATIONS

When the coil is de–energized, this valve allows flow and pressure from port 1 to port 2 if pressure exceeds the spring bias (50 psi). When the coil is energized the armature moves a precision bias spring against the pilot orifice thus varying the pressure setting at port 1 proportional to the current input. When the current is increased to the coil the relief pressure will increase and when decreased it will decrease. IN THE EVENT OF POWER FAILURE THE VALVE RELIEF PRESSURE SETTING AT PORT 1 WILL BE THE SPRING BIAS.

FEATURES AND BENEFITS

Continuous–duty, very low heat rise & waterproof solenoid coil.
Pressure in tank port (2) will add to the bias spring setting, and is limited to 2000 PSI.
Interchangeable solenoid coils & terminations options available.
Hardened precision fitted spool & sleeve provides reliable, long life.
A unique self aligning (floating) cage provides very low hysteresis and reliable operation.
Very efficient wet – armature solenoid core tube construction.
All external carbon steel parts are plated for longer life against the elements.
All cartridge valves are 100% functionally tested.
Industry common cavity.

**ELECTRO-HYDRAULIC, PROPORTIONAL,
PRESSURE RELIEF VALVE.****SPECIFICATIONS**

OPERATING PRESSURE: 5000 PSI [350 Bar]

PROOF PRESSURE: 10,000 PSI [700 Bar]

REGULATED PRESSURE: 50 to 5000 PSI [3,5 to 345] See performance chart.

FLOW: 25.0 GPM [95,0 L/M] nominal.

INTERNAL PILOT FLOW: 60 cu.in/min [1,0 l/m] @ 3000 PSI [210 Bar]

VALVE HOUSINGS: 2500 PSI [175 Bar] = Aluminum - Anodized.

5000 PSI [350 Bar] = Steel - Unplated.

OPERATING TEMPERATURE: -40° to +250° F. [-40° to +120° C.]

OPERATING MEDIA: All general purpose hydraulic fluids such as
MIL-H-5606, SAE-#10, SAE-#20, etc.

RESPONSE: The most efficient method to control this valve is with
current control and a 50 Hz dither.

POWER REQUIREMENTS: 12 VDC, Operating current 0.2 to 2.4 AMPS.
24 VDC, Operating current 0.1 to 1.2 AMPS.

SEAL KIT: SKN-1022 Buna "N"
SKV-1022 Viton

INSTALLATION: No restrictions.

WEIGHT: 1.95 lb [.88 kg] cartridge with coil only.

VALVE CAVITY: #C1020, See Page 0-012.0.

PROPORTIONAL PRESSURE RELIEF VALVE.
PILOT OPERATED, SLIDING SPOOL TYPE.

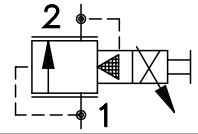

Pat.#5,546,980

TORQUE:

Steel = 70/75 Ft-Lb. [95/102 Nm]
Aluminum = 55/60 Ft-Lb. [74/81 Nm]

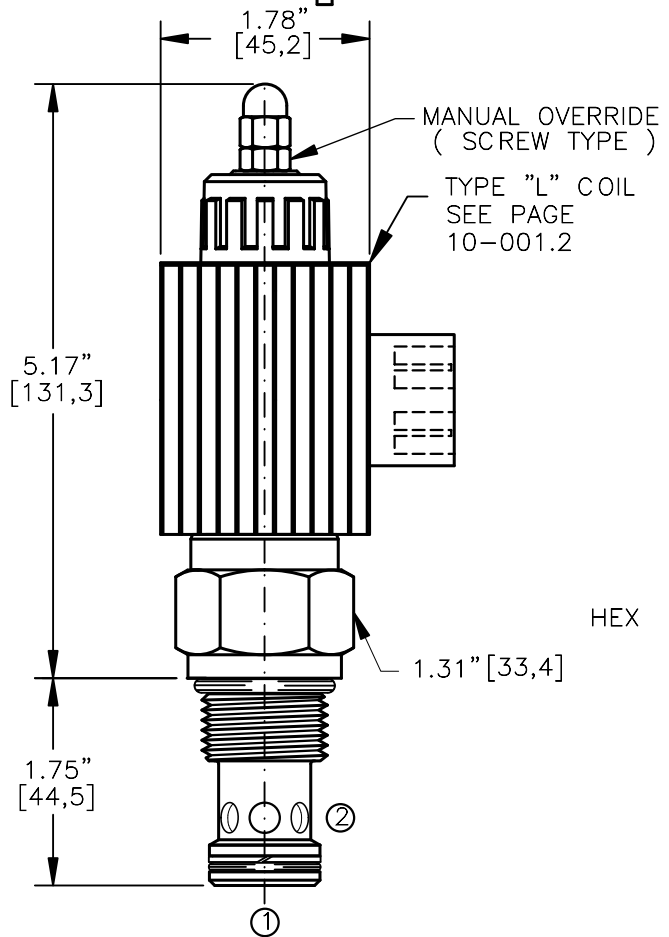
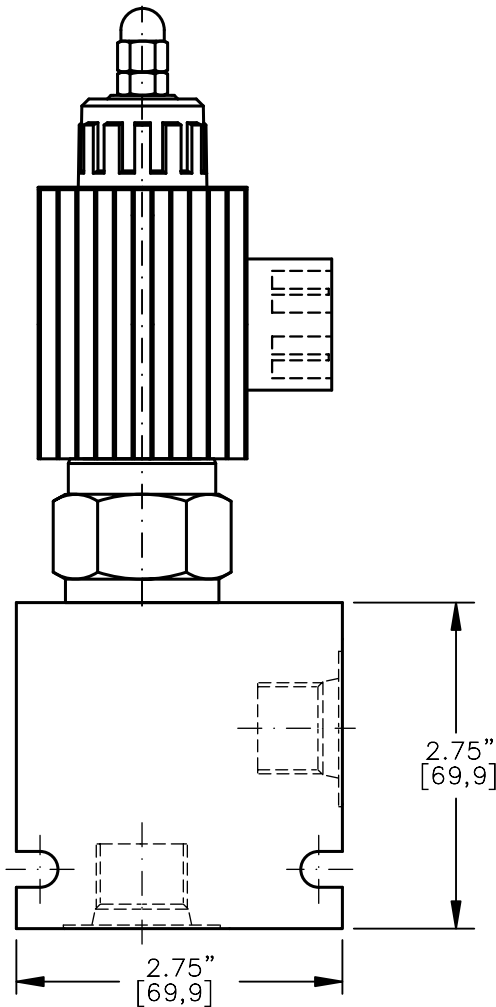

NOTES:

- FOR ALUMINUM OR STEEL VALVE HOUSING CONFIGURATIONS SEE PAGE 0-013.1
- SOLENOIDS AVAILABLE WITH DIODES - CONSULT FACTORY.

ERVP-12-X-XX-X-X-XXX X

BASIC

SIZE
12 = 1.062"-12UNF

SEALS
N = BUNA "N"
V = VITON

REGULATED PRESSURE
15 = 50 TO 1500 PSI
30 = 50 TO 3000 PSI
50 = 50 TO 5000 PSI

TERMINALS
L = 18GA. 24" LEADS
T = SPADE TERM.
B = BOLT TERM.
G = DIN43650
W = WEATHER-PACK
D = DEUTSCH-DT04-2P
M = METRI-PACK CONN.
VOLTAGE AMPS
12D = 12 VDC 3.00
24D = 24 VDC 1.50

ADJUSTMENT OPTIONS
M = MANUAL OVERRIDE

PORTS
0 = CARTRIDGE
4BX = G 1/2" BSPP
6BX = G 3/4" BSPP
10TX = SAE - #10
12TX = SAE - #12
"A" - ALUM. HOUSING
"S" - STEEL HOUSING

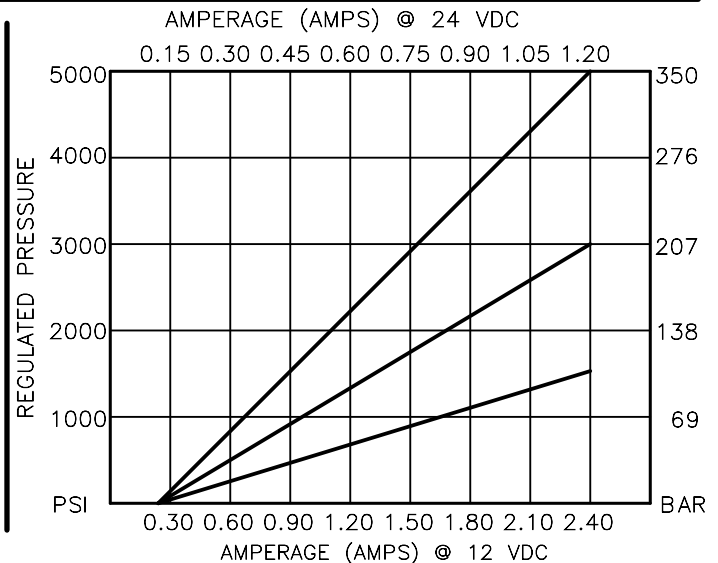

ELECTRO-HYDRAULIC, PROPORTIONAL, PRESSURE RELIEF VALVE.

DESCRIPTION

This unit is a electro-hydraulic, proportional, screw in cartridge style, pilot operated, sliding spool type, high pressure relief valve.

OPERATIONS

When the coil is de-energized, this valve allows flow and pressure from port 1 to port 2 if pressure exceeds the spring bias (50 psi). When the coil is energized the armature moves a precision bias spring against the pilot orifice thus varying the pressure setting at port 1 proportional to the current input. When the current is increased to the coil the relief pressure will increase and when decreased it will decrease. IN THE EVENT OF POWER FAILURE THE VALVE RELIEF PRESSURE SETTING AT PORT 1 WILL BE THE SPRING BIAS.

FEATURES AND BENEFITS

Continuous-duty, very low heat rise & waterproof solenoid coil.
Pressure in tank port (2) will add to the bias spring setting, and is limited to 2000 PSI.
Interchangeable solenoid coils & terminations options available.
Hardened precision fitted spool & sleeve provides reliable, long life.
A unique self aligning (floating) cage provides very low hysteresis and reliable operation.
Very efficient wet – armature solenoid core tube construction.
All external carbon steel parts are plated for longer life against the elements.
All cartridge valves are 100% functionally tested.

**ELECTRO-HYDRAULIC, PROPORTIONAL,
PRESSURE RELIEF VALVE.**

SPECIFICATIONS

OPERATING PRESSURE: 5000 PSI [350 Bar]

PROOF PRESSURE: 10,000 PSI [700 Bar]

REGULATED PRESSURE: 50 to 5000 PSI [3,5 to 345] See performance chart.

FLOW: 60.0 GPM [227,0 L/M] nominal.

INTERNAL PILOT FLOW: 60 cu.in/min [1,0 l/m] @ 3000 PSI [210 Bar]

VALVE HOUSINGS: 2500 PSI [175 Bar] = Aluminum – Anodized.

5000 PSI [350 Bar] = Steel – Unplated.

OPERATING TEMPERATURE: -40° to +250° F. [-40° to +120° C.]

OPERATING MEDIA: All general purpose hydraulic fluids such as
MIL-H-5606, SAE-#10, SAE-#20, etc.

RESPONSE: The most efficient method to control this valve is with
current control and a 50 Hz dither.

POWER REQUIREMENTS: 12 VDC, Operating current 0.2 to 2.4 AMPS.

24 VDC, Operating current 0.1 to 1.2 AMPS.

SEAL KIT: SKN-1222 Buna "N"

SKV-1222 Viton

INSTALLATION: No restrictions.

WEIGHT: 2.25 lb [1,12 kg] cartridge with coil only.

VALVE CAVITY: #C1220, See Page 0-013.0.

info.el@bucherhydraulics.com

www.bucherhydraulics.com/commoncavity

© 2015 by Bucher Hydraulics, Inc., 2545 Northwest Parkway, Elgin, Illinois 60124, USA

All rights reserved.

The technical information in this catalog, may contain calculated figures (for reference only) and not actual performance data for this product.

Data is provided for the purpose of product description only, and must not be construed as warranted characteristics in the legal sense.

The information does not relieve users from the duty of conducting their own evaluations and tests. Because the products are subject to continual improvement, we reserve the right to amend the product specifications contained in this catalogue.

PROPORTIONAL PRESSURE RELIEF VALVE.
DIRECT ACTING, LOW FLOW, POPPET TYPE.

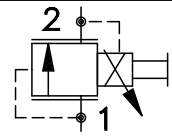

Pat.#5,546,980

TORQUE:

Steel = 55/60 Ft-Lb. [74/81 Nm]
Aluminum = 35/40 Ft-Lb. [47/54 Nm]

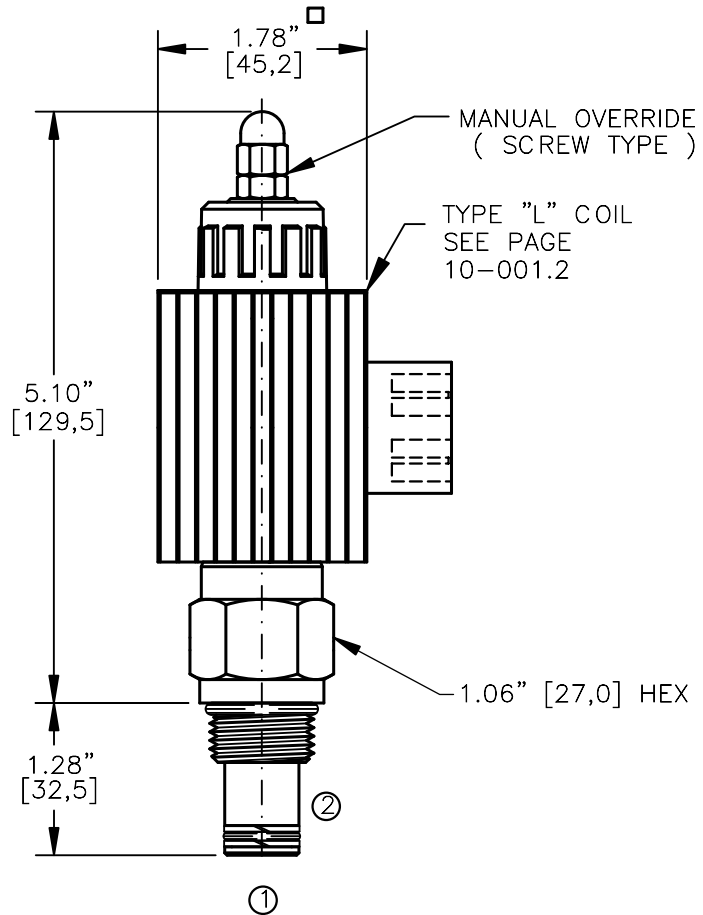
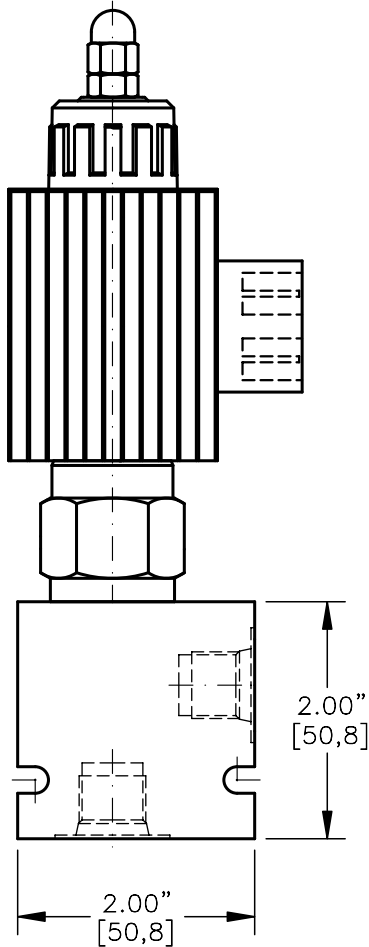

NOTES:

- FOR ALUMINUM OR STEEL VALVE HOUSING CONFIGURATIONS SEE PAGE 0-012.1
- SOLENOIDS AVAILABLE WITH DIODES - CONSULT FACTORY.

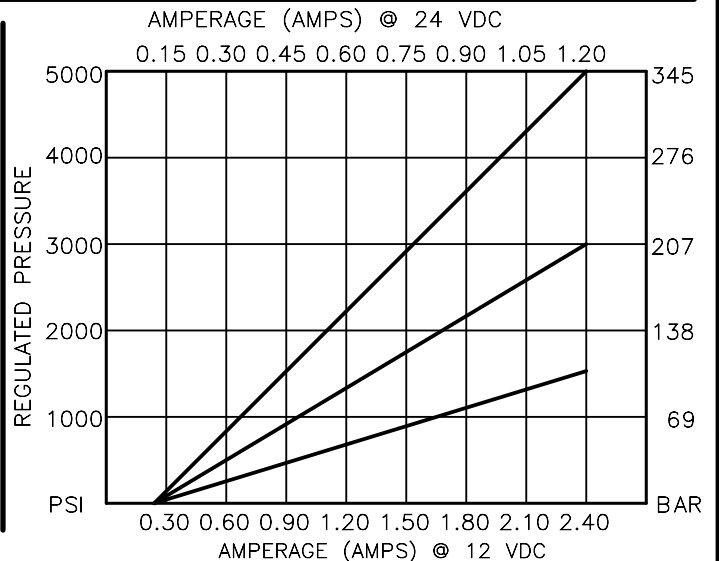
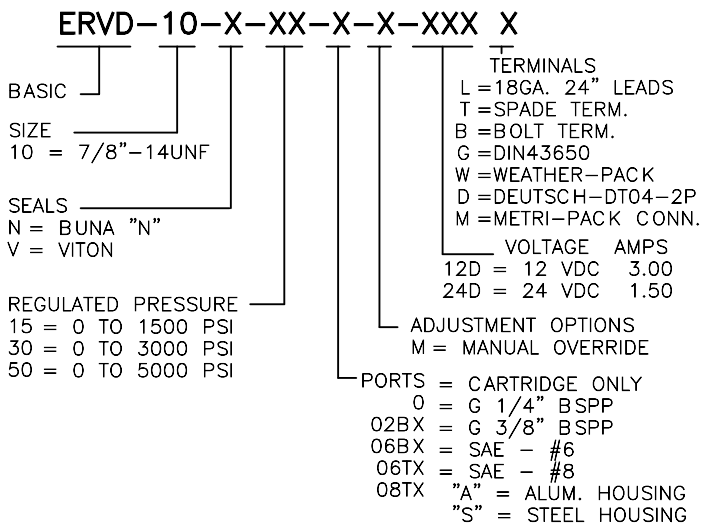

ELECTRO-HYDRAULIC, PROPORTIONAL, PRESSURE RELIEF VALVE.

DESCRIPTION

This unit is a electro-hydraulic, proportional, screw in cartridge style, direct acting, low flow, poppet type, high pressure relief valve.

OPERATIONS

When the coil is de-energized, this valve allows flow and pressure from port 1 to port 2 (tank).

When the coil is energized the armature moves a precision bias spring against the metering poppet thus varying the pressure at port 1 proportional to the current input. When the current is increased to the coil the pressure will increase and when decreased it will decrease.

IN THE EVENT OF POWER FAILURE THE VALVE WILL REDUCE REGULATED PRESSURE AT PORT 1 TO 0 PSI.

FEATURES AND BENEFITS

Continuous-duty, very low heat rise & waterproof solenoid coil.

Pressure in tank port (2) will add to the bias spring setting, and is limited to 2000 PSI.

Interchangeable solenoid coils & terminations options available.

Hardened precision poppet & pilot seat provides reliable, long life.

A unique self aligning (floating) cage provides very low hysteresis and reliable operation.

Very efficient wet - armature solenoid core tube construction.

All external carbon steel parts are plated for longer life against the elements.

All cartridge valves are 100% functionally tested.

Industry common cavity.

**ELECTRO-HYDRAULIC, PROPORTIONAL,
PRESSURE RELIEF VALVE.****SPECIFICATIONS**

OPERATING PRESSURE: 5000 PSI [350 Bar]

PROOF PRESSURE: 10,000 PSI [700 Bar]

REGULATED PRESSURE: 0 to 5000 PSI [0 to 350] See performance chart.

FLOW: 1.0 GPM [3.8 L/M] nominal.

VALVE HOUSINGS: 2500 PSI [175 Bar] = Aluminum – Anodized.

5000 PSI [350 Bar] = Steel – Unplated.

OPERATING TEMPERATURE: -40° to +250° F. [-40° to +120° C.]

OPERATING MEDIA: All general purpose hydraulic fluids such as
MIL-H-5606, SAE-#10, SAE-#20, etc.

RESPONSE: The most efficient method to control this valve is with
24 VDC, Operating current 0.1 to 1.2 AMPS.

POWER REQUIREMENTS: 12 VDC, Operating current 0.2 to 2.4 AMPS.
current control and a 50 Hz dither.

SEAL KIT: SKN-1022 Buna "N"

SKV-1022 Viton

INSTALLATION: No restrictions.

WEIGHT: 1.95 lb [.88 kg] cartridge with coil only.

VALVE CAVITY: #C1020, See Page 0-012.0.

info.el@bucherhydraulics.com

www.bucherhydraulics.com/commoncavity

© 2015 by Bucher Hydraulics, Inc., 2545 Northwest Parkway, Elgin, Illinois 60124, USA

All rights reserved.

The technical information in this catalog, may contain calculated figures (for reference only) and not actual performance data for this product.

Data is provided for the purpose of product description only, and must not be construed as warranted characteristics in the legal sense.

The information does not relieve users from the duty of conducting their own evaluations and tests. Because the products are subject to continual improvement, we reserve the right to amend the product specifications contained in this catalogue.

ELECTRO-HYDRAULIC, PROPORTIONAL,
PRESSURE COMP, FLOW CONTROL VALVE.

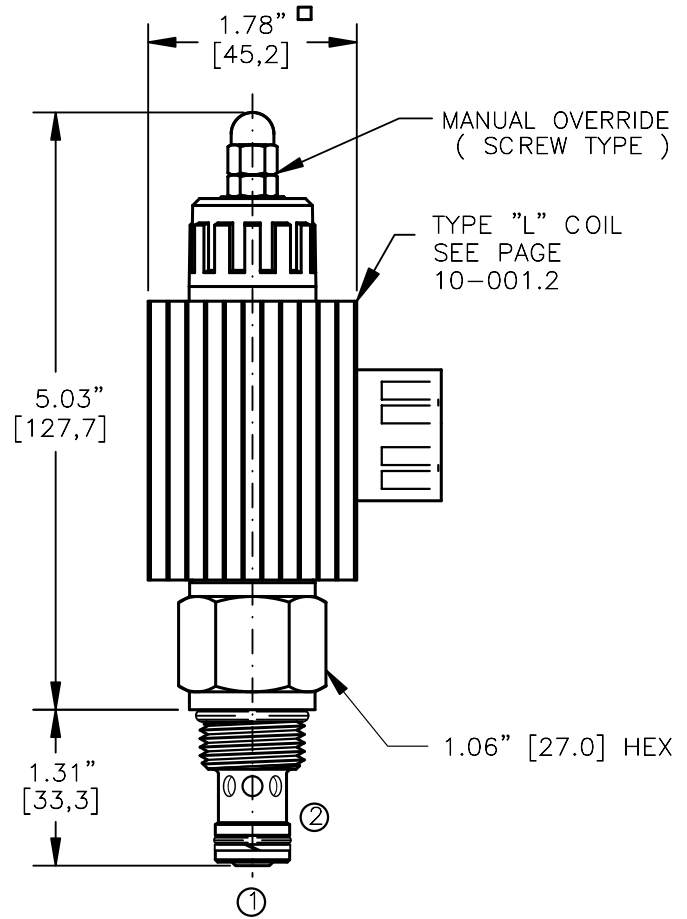
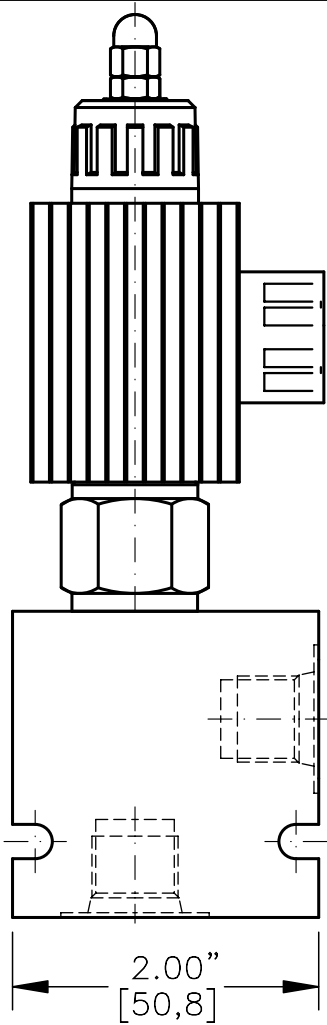
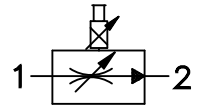

TORQUE:
Steel = 55/60 Ft-Lb. [74/81 Nm]
Aluminum = 35/40 Ft-Lb. [47/54 Nm]

NOTES:

- FOR ALUMINUM OR STEEL VALVE HOUSING CONFIGURATIONS SEE PAGE 0-012.1
- SOLENOIDS AVAILABLE WITH DIODES - CONSULT FACTORY.

EPFI-10-X-X-XX-X-X-XXX X

- BASIC
- SIZE
10 = 7/8"-14UNF
- SEALS
N = BUNA "N"
V = VITON
- STYLE
C = NORMALLY CLOSED
O = NORMALLY OPEN
- REGULATED FLOW
04 = 0 TO 4.0 GPM
08 = 0 TO 8.0 GPM
- TERMINALS
L = 18GA. 24" LEADS
T = SPADE TERM.
B = BOLT TERM.
G = DIN43650
W = WEATHER-PACK
D = DEUTSCH-DT04-2P
M = METRI-PACK CONN.
- VOLTAGE AMPS
12D = 12 VDC 3.00
24D = 24 VDC 1.50
- ADJUSTMENT OPTIONS
O = NONE
M = MANUAL OVERRIDE
- PORTS = CARTRIDGE ONLY
O = G 1/4" BSPP
02BX = G 3/8" BSPP
06BX = SAE - #6
06TX = SAE - #8
08TX "A" = ALUM. HOUSING
"S" = STEEL HOUSING

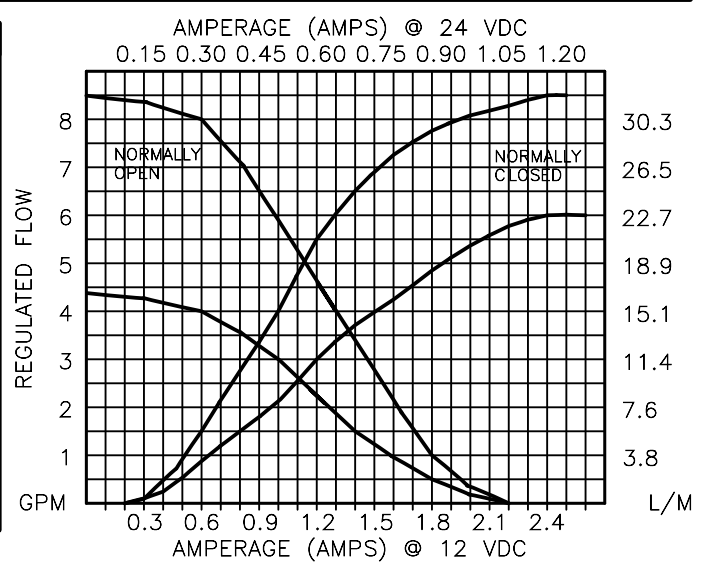

PROPORTIONAL, PRESSURE COMPENSATED, FLOW CONTROL VALVE.

DESCRIPTION

This valve is a cartridge style, electro-hydraulic, proportional, in-line (RESTRICTIVE) type, pressure compensated, hydraulic flow control. Regulated flow 8.0 GPM [30,2 L/M] max. is proportional to the current input regardless of load or system pressure.

OPERATIONS

This unit is a direct acting (NO PILOT FLOW), electro hydraulic, proportional, pressure compensated flow control valve. When the coil is energized the armature moves the metering orifice open against a precision bias spring varying the flow. A pressure compensatory spool (HYDROSTAT) modulates the flow at 100 PSI/6,9 Bar delta "P" providing the valve with a constant regulated flow regardless of load or system pressure. For the normally closed product when the current is increased to the coil the flow will increase. For the normally open product as the current is increased to the coil the flow will decrease. IN THE EVENT OF POWER FAILURE THE NORMALLY CLOSED VALVE WILL CLOSE AND THE NORMALLY OPEN VALVE WILL OPEN.

FEATURES AND BENEFITS

Continuous-duty, very low heat rise & waterproof solenoid coil.
Interchangeable solenoid coils & termination options available.
Hardened precision fitted spool & sleeve provides reliable, long life.
Very efficient wet – armature solenoid core tube construction.
All external carbon steel parts are plated for longer life against the elements.
All cartridge valves are 100% functionally tested.

PROPORTIONAL, PRESSURE COMPENSATED,
FLOW CONTROL VALVE.

SPECIFICATIONS

OPERATING PRESSURE: 5,000 PSI [350 Bar]

PROOF PRESSURE: 10,000 PSI [700 Bar]

REGULATED FLOW: 8.0 GPM [30,2 l/m] Max. See performance chart.

INTERNAL LEAKAGE: 20/40 in³/min [328/655 cc/m]@3/5K PSI [175/350 Bar]

VALVE HOUSINGS: 2500 PSI [175 Bar] = Aluminum – Anodized.

5000 PSI [350 Bar] = Steel – Unplated.

OPERATING TEMPERATURE: -40° to +250° F. [-40° to +120° C.]

OPERATING MEDIA: All general purpose hydraulic fluids such as
MIL-H-5606, SAE-#10, SAE-#20, etc.

RESPONSE: The most efficient method to control this valve is with
current control and a 50 Hz dither.

POWER REQUIREMENTS: 12 VDC, Operating current 0.2 to 2.2 AMPS.

24 VDC, Operating current 0.1 to 1.1 AMPS.

SEAL KIT: SKN-1022 Buna "N"

SKV-1022 Viton

INSTALLATION: No restrictions.

WEIGHT: 1.9 lb [0,86 kg] cartridge with coil only.

VALVE CAVITY: #C1020, See Page 0-012.0.

info.el@bucherhydraulics.com

www.bucherhydraulics.com/commoncavity

© 2015 by Bucher Hydraulics, Inc., 2545 Northwest Parkway, Elgin, Illinois 60124, USA

All rights reserved.

The technical information in this catalog, may contain calculated figures (for reference only) and not actual performance data for this product.

Data is provided for the purpose of product description only, and must not be construed as warranted characteristics in the legal sense.

The information does not relieve users from the duty of conducting their own evaluations and tests. Because the products are subject to continual improvement, we reserve the right to amend the product specifications contained in this catalogue.

ELECTRO-HYDRAULIC, PROPORTIONAL,
PRESSURE COMP, FLOW CONTROL VALVE.

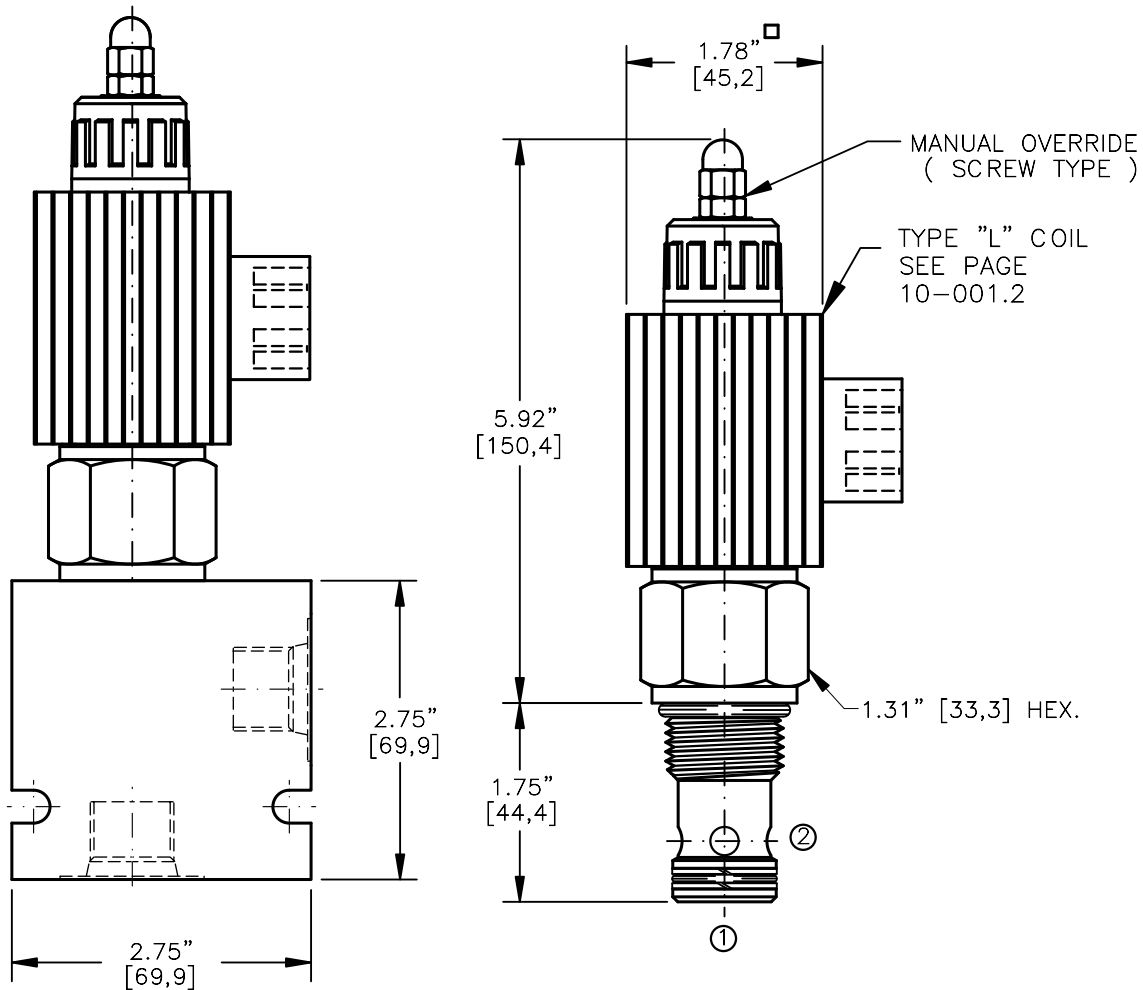
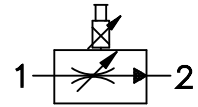

NOTES:
SOLENOIDS AVAILABLE WITH DIODES - CONSULT FACTORY.

TORQUE
Steel = 75/80 Ft-Lb. [102/109 Nm]
Aluminum = 55/60 Ft-Lb. [74/81 Nm]

EPFI-12-N-X-XX-X-X-XXX X

BASIC
SIZE
12=1.062"-12UNF

SEALS
N = BUNA "N"
V = VITON

TYPE
C = NORMALLY CLOSED
O = NORMALLY OPEN

REGULATED FLOW
05 = 0 TO 5.0 GPM
10 = 0 TO 10.0 GPM
15 = 0 TO 15.0 GPM

TERMINALS
L=18GA. 24" LEADS
T=SPADE TERM.
B=BOLT TERM.
G=DIN43650
W=WEATHER-PACK
D=DEUTSCH-DT04-2P
M=METRI-PACK CONN

VOLTAGE AMPS
12D = 12 VDC 3.00
24D = 24 VDC 1.50

ADJUSTMENT OPTIONS
0 = NONE
M = MANUAL OVERRIDE

PORTS
0 = CARTRIDGE
4BX = G 1/2" BSPP
6BX = G 3/4" BSPP
10TX = SAE - #10
12TX = SAE - #12

"A" - ALUM. HOUSING
"S" - STEEL HOUSING

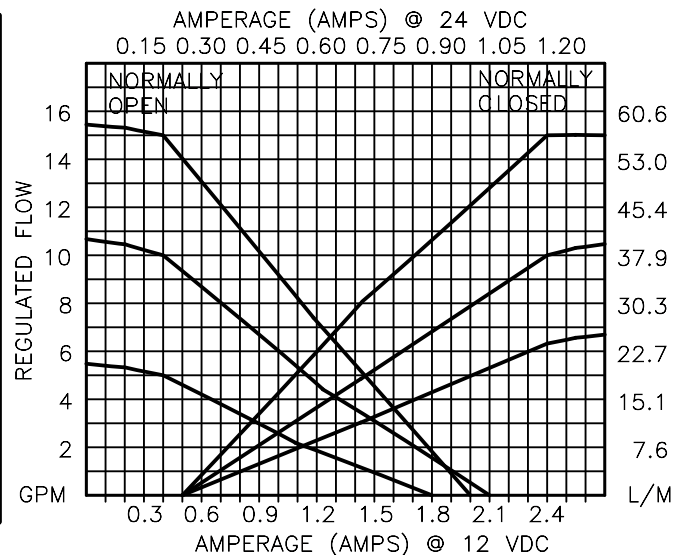

**PROPORTIONAL, PRESSURE COMPENSATED,
FLOW CONTROL VALVE.**

DESCRIPTION

This valve is a cartridge style, electro-hydraulic, proportional, in-line (RESTRICTIVE) type, pressure compensated, hydraulic flow control. Regulated flow 15.0 GPM [56,8 l/m] max. is proportional to the current input regardless of load or system pressure.

OPERATIONS

This unit is a direct acting (NO PILOT FLOW), electro hydraulic, proportional, pressure compensated flow control valve. When the coil is energized, the armature moves the metering orifice open against a precision bias spring varying the flow. A pressure compensator spool (HYDROSTAT) modulates the flow at 100 PSI/6,9 Bar delta "P" providing the valve with a constant regulated flow regardless of load or system pressure. For the normally closed product when the current is increased to the coil, the flow will increase. For the normally open product as the current is increased to the coil the flow will decrease. IN THE EVENT OF POWER FAILURE, THE NORMALLY CLOSED VALVE WILL CLOSE AND THE NORMALLY OPEN VALVE WILL OPEN.

FEATURES AND BENEFITS

Continuous-duty, very low heat rise & waterproof solenoid coil.
Interchangeable solenoid coils & termination options available.
Hardened precision fitted spool & sleeve provides reliable, long life.
Very efficient wet – armature solenoid core tube construction.
All external carbon steel parts are plated for longer life against the elements.
All cartridge valves are 100% functionally tested.

PROPORTIONAL, PRESSURE COMPENSATED,
FLOW CONTROL VALVE.

SPECIFICATIONS

OPERATING PRESSURE: 5,000 PSI [350 Bar]

PROOF PRESSURE: 10,000 PSI [700 Bar]

REGULATED FLOW: 15.0 GPM [56,8 l/m] Max. See performance chart.

INTERNAL LEAKAGE: 20/40 in³/min [328/655 cc/m] @ 3/5K PSI [175/350 Bar]

VALVE HOUSINGS: 2500 PSI [175 Bar] = Aluminum – Anodized.

5000 PSI [350 Bar] = Steel – Unplated.

OPERATING TEMPERATURE: -40° to +250° F. [-40° to +120° C.]

OPERATING MEDIA: All general purpose hydraulic fluids such as
MIL-H-5606, SAE-#10, SAE-#20, etc.

RESPONSE: The most efficient method to control this valve is with
current control and a 50 Hz dither.

POWER REQUIREMENTS: 12 VDC, Operating current 0.2 to 2.2 AMPS.

24 VDC, Operating current 0.1 to 1.1 AMPS.

SEAL KIT: SKN-1222 Buna "N"

SKV-1222 Viton

INSTALLATION: No restrictions.

WEIGHT: 2.27 lb [1,03 kg] cartridge with coil only.

VALVE CAVITY: #C1220, See Page 0-013.0.

info.el@bucherhydraulics.com

www.bucherhydraulics.com/commoncavity

© 2015 by Bucher Hydraulics, Inc., 2545 Northwest Parkway, Elgin, Illinois 60124, USA

All rights reserved.

The technical information in this catalog, may contain calculated figures (for reference only) and not actual performance data for this product.

Data is provided for the purpose of product description only, and must not be construed as warranted characteristics in the legal sense.

The information does not relieve users from the duty of conducting their own evaluations and tests. Because the products are subject to continual improvement, we reserve the right to amend the product specifications contained in this catalogue.

ELECTRO-HYDRAULIC, PROPORTIONAL, IN-LINE,
PRESSURE COMP, FLOW CONTROL VALVE.

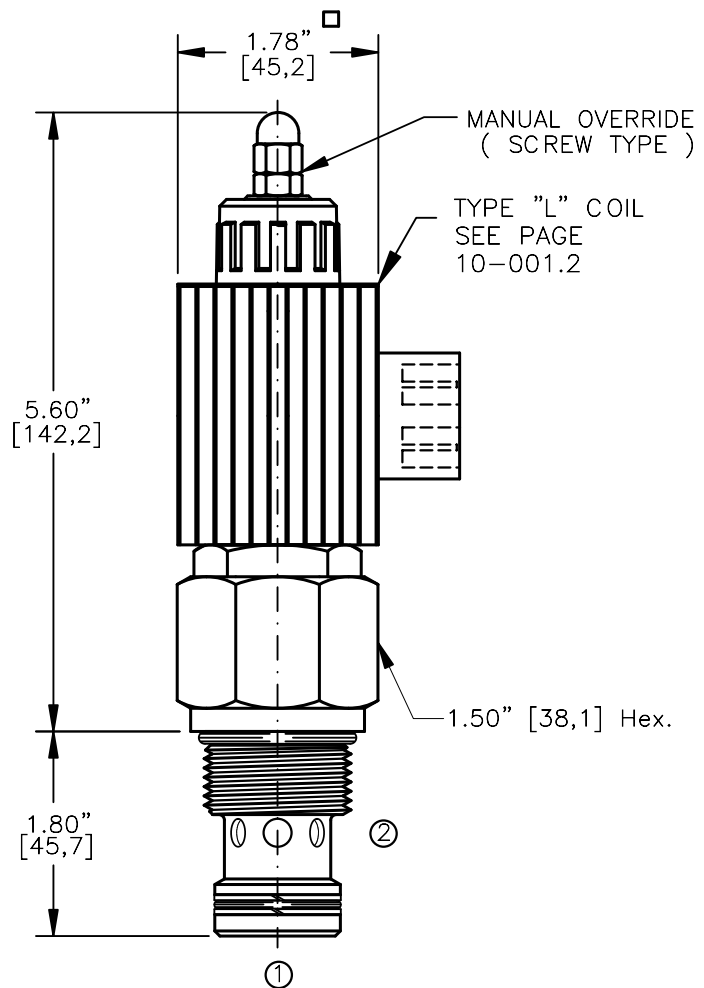
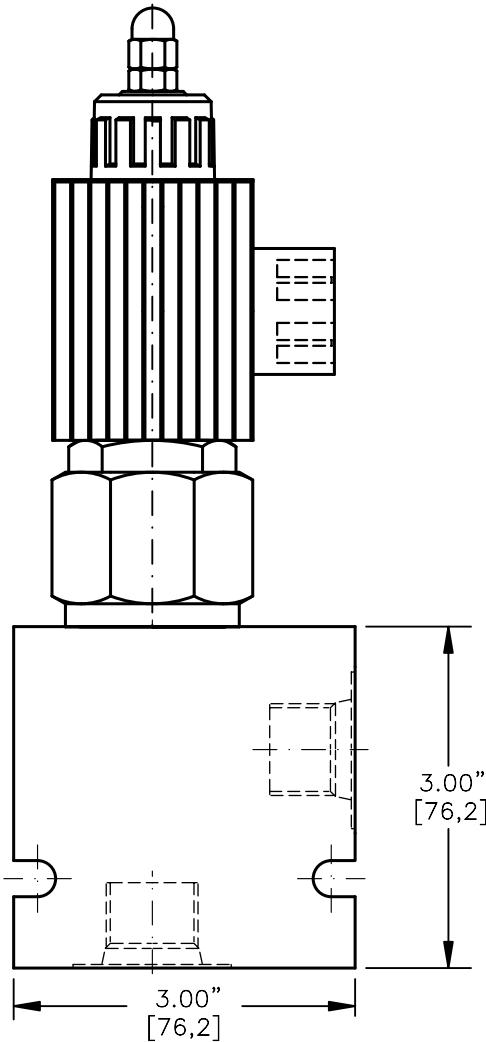
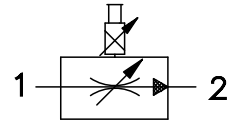

TORQUE:

Steel = 95/100 Ft-Lb. [129/136 Nm]
Aluminum = 70/75 Ft-Lb. [95/102 Nm]

EPFC-16-X-XX-X-X-XXX X

- BASIC
- SIZE
16 = 1.312"-12UNF
- SEALS
N = BUNA "N"
V = VITON
- REGULATED FLOW
05 = 0 TO 5.0 GPM
10 = 0 TO 10.0 GPM
15 = 0 TO 15.0 GPM
20 = 0 TO 20.0 GPM
- TERMINALS
L = 18GA. 24" LEADS
T = SPADE TERM.
B = BOLT TERM.
G = DIN43650
W = WEATHER-PACK
D = DEUTSCH-DT04-2P
M = METRI-PACK CONN.
- VOLTAGE AMPS
12D = 12 VDC 3.00
24D = 24 VDC 1.50
- ADJUSTMENT OPTIONS
M = MANUAL OVERRIDE
- PORTS = CARTRIDGE ONLY
0 = G 3/4" BSPP
06BX = G 1" BSPP
08BX = SAE - #12
12TX = SAE - #16
16TX "A" = ALUM. HOUSING
"S" = STEEL HOUSING

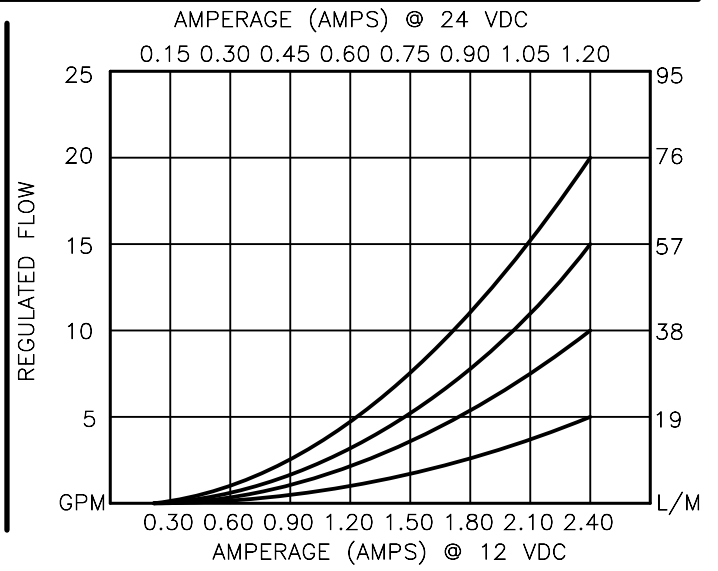

PROPORTIONAL, IN-LINE TYPE, FLOW CONTROL VALVE.**DESCRIPTION**

This valve is a cartridge style, electro-hydraulic, proportional, in-line (RESTRICTIVE) type, pressure compensated, hydraulic flow control. Regulated flow 20.0 GPM [76,0 L/M] max. is proportional to the current input regardless of load or system pressure.

OPERATIONS

This unit is a direct acting (NO PILOT FLOW), electro hydraulic, proportional, pressure compensated, flow control valve. When the coil is energized the armature moves the metering orifice open against a precision bias spring varying the flow. A pressure compensator spool (HYDROSTAT) modulates the flow at 100 PSI/6,9 Bar delta "P" providing the valve with a constant regulated flow regardless of load or system pressure. When current is increased to the coil the flow will increase, as the current is decreased the flow will decrease proportionally. IN THE EVENT OF POWER FAILURE THE VALVE WILL CLOSE.

FEATURES AND BENEFITS

Continuous-duty, very low heat rise & waterproof solenoid coil.
Interchangeable solenoid coils & terminations options available.
Hardened precision fitted spool & sleeve provides reliable, long life.
Very efficient wet – armature solenoid core tube construction.
All external carbon steel parts are plated for longer life against the elements.
All cartridge valves are 100% functionally tested.
Industry common cavity.

PROPORTIONAL, IN-LINE TYPE, FLOW CONTROL VALVE.**SPECIFICATIONS**

OPERATING PRESSURE: 5,000 PSI [350 Bar]

PROOF PRESSURE: 10,000 PSI [700 Bar]

REGULATED FLOW: 20.0 GPM [76,0 l/m] Max. See performance chart.

INTERNAL LEAKAGE: 20 cu.in/min [330 cc/m] @ 5,000 PSI [350 Bar]

VALVE HOUSINGS: 2500 PSI [175 Bar] = Aluminum – Anodized.

5000 PSI [350 Bar] = Steel – Unplated.

OPERATING TEMPERATURE: -40° to +250° F. [-40° to +120° C.]

OPERATING MEDIA: All general purpose hydraulic fluids such as

MIL-H-5606, SAE-#10, SAE-#20, etc.

RESPONSE: The most efficient method to control this valve is with current control and a 50 Hz dither.

POWER REQUIREMENTS: 12 VDC, Operating current 0.2 to 2.2 AMPS.

24 VDC, Operating current 0.1 to 1.1 AMPS.

SEAL KIT: SKN-1622 Buna "N"

SKV-1622 Viton

INSTALLATION: No restrictions.

WEIGHT: 2.58 lb [1,17 kg] cartridge with coil only.

VALVE CAVITY: #C1620, See Page 0-014.0.

info.el@bucherhydraulics.com

www.bucherhydraulics.com/commoncavity

© 2015 by Bucher Hydraulics, Inc., 2545 Northwest Parkway, Elgin, Illinois 60124, USA

All rights reserved.

The technical information in this catalog, may contain calculated figures (for reference only) and not actual performance data for this product.

Data is provided for the purpose of product description only, and must not be construed as warranted characteristics in the legal sense.

The information does not relieve users from the duty of conducting their own evaluations and tests. Because the products are subject to continual improvement, we reserve the right to amend the product specifications contained in this catalogue.

ELECTRO-HYDRAULIC, PROPORTIONAL, PRIORITY,
PRESSURE COMP, FLOW CONTROL VALVE.

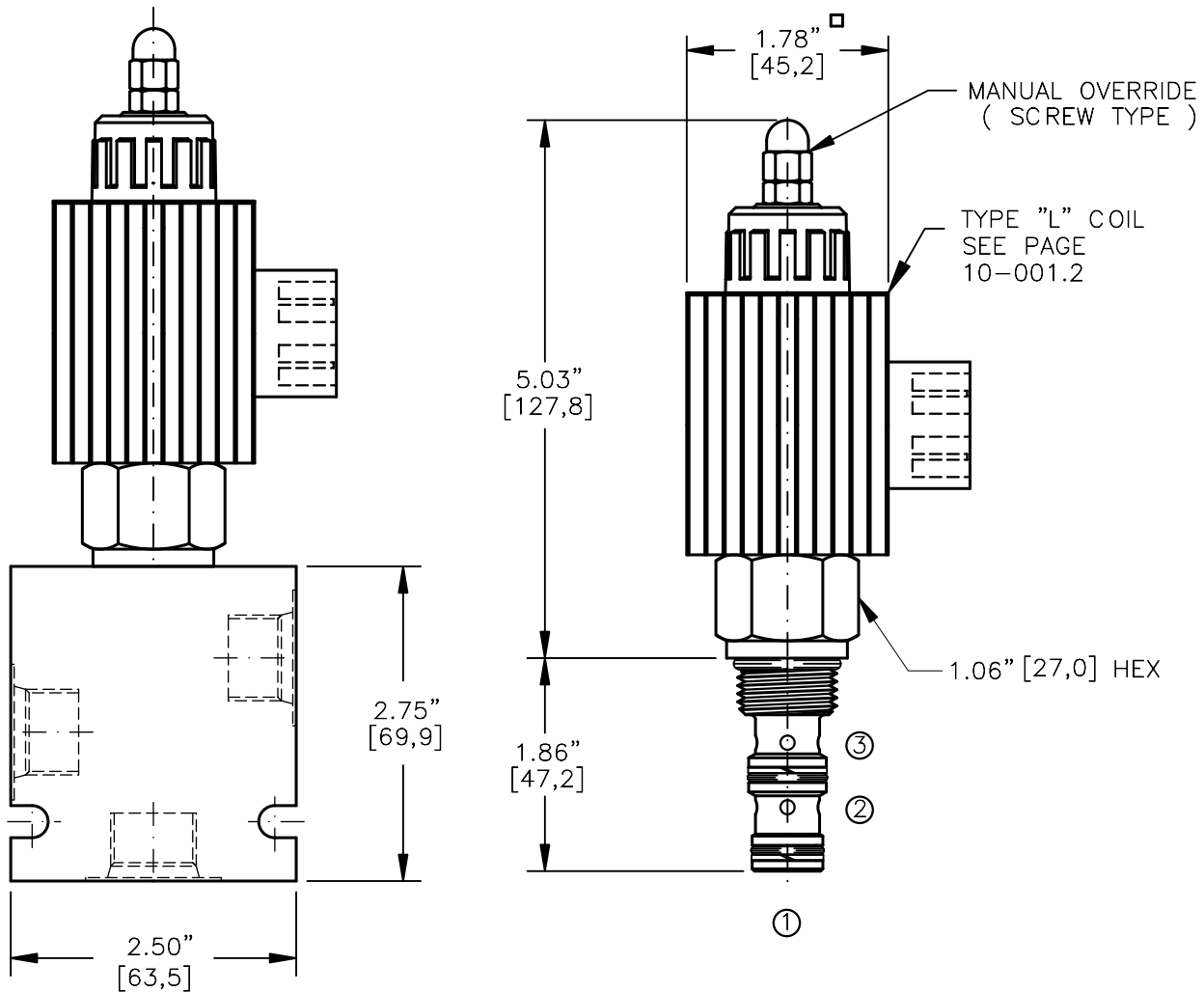
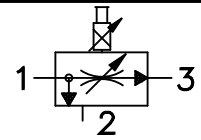

TORQUE:

Steel = 55/60 Ft-Lb. [74/81 Nm]
Aluminum = 35/40 Ft-Lb. [47/54 Nm]

EPFB-10-X-X-XX-X-X-XXX X

BASIC

SIZE

10=0.875"-14UNF

SEALS

N = BUNA "N"

V = VITON

STYLE

C = NORMALLY CLOSED

O = NORMALLY OPEN

REGULATED FLOW

04 = 0 TO 4.0 GPM

08 = 0 TO 8.0 GPM

"A" - ALUM. HOUSING

"S" - STEEL HOUSING

TERMINALS

L=18GA. 24" LEADS

T=SPADE TERM.

B=BOLT TERM.

G=DIN43650

W=WEATHER-PACK

D=DEUTSCH-DT04-2P

M=METRI-PACK CONN

VOLTAGE AMPS

12D = 12 VDC 3.00

24D = 24 VDC 1.50

ADJUSTMENT OPTIONS

0 = NONE

M = MANUAL OVERRIDE

PORTS

0 = CARTRIDGE

2BX = G 1/4" BSPP

3BX = G 3/8" BSPP

6TX = SAE - #6

8TX = SAE - #8

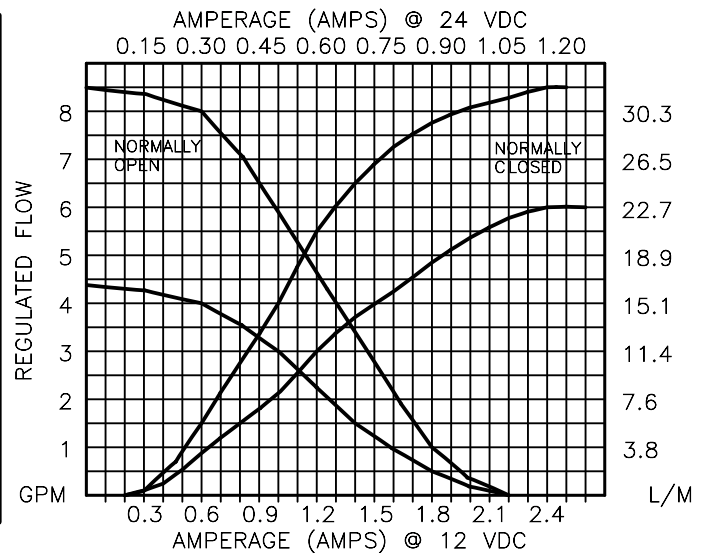

PROPORTIONAL, PRIORITY TYPE, PRESSURE COMP,
FLOW CONTROL VALVE.

DESCRIPTION

This valve is a cartridge style, electro-hydraulic, proportional, priority (BY-PASS) type, pressure compensated, hydraulic flow control. Regulated flow 8.0 GPM [30,3 L/M] max. is proportional to the current input regardless of load or system pressure. After the priority flow is satisfied the excess flow is diverted to a secondary circuit or to tank. Maximum inlet flow is 10.0 GPM [37,9 L/M].

OPERATIONS

This unit is a direct acting (NO PILOT FLOW), electro hydraulic, proportional, pressure compensated flow control valve. When the coil is energized, the armature moves the metering orifice open against a precision bias spring varying the flow. A pressure compensator spool (HYDROSTAT) modulates the flow at 100 PSI/6,9 Bar delta "P" providing the valve with a constant regulated flow regardless of load or system pressure. For the normally closed product when the current is increased to the coil, the flow will increase. For the normally open product as the current is increased to the coil the flow will decrease. IN THE EVENT OF POWER FAILURE, THE NORMALLY CLOSED VALVE WILL CLOSE AND THE NORMALLY OPEN VALVE WILL OPEN.

FEATURES AND BENEFITS

Continuous-duty, very low heat rise & waterproof solenoid coil.
Interchangeable solenoid coils & termination options available.
Hardened precision fitted spool & sleeve provides reliable, long life.
Very efficient wet – armature solenoid core tube construction.
All external parts are zinc plated for longer life against elements.
All cartridge valves are 100% functionally tested.

PROPORTIONAL, PRIORITY TYPE, PRESSURE COMP,
FLOW CONTROL VALVE.

SPECIFICATIONS

OPERATING PRESSURE: 5,000 PSI [350 Bar]

PROOF PRESSURE: 10,000 PSI [700 Bar]

REGULATED FLOW: 8.0 GPM [30,3 l/m] Max. See performance chart.

INTERNAL LEAKAGE: 20 cu.in/min [328 cc/m] @ 5,000 PSI [350 Bar]

VALVE HOUSINGS: 2500 PSI [175 Bar] = Aluminum - Anodized.

5000 PSI [350 Bar] = Steel - Unplated.

OPERATING TEMPERATURE: -40° to +250° F. [-40° to +120° C.]

OPERATING MEDIA: All general purpose hydraulic fluids such as
MIL-H-5606, SAE-#10, SAE-#20, etc.

RESPONSE: The most efficient method to control this valve is with
current control and a 50 Hz dither.

POWER REQUIREMENTS: 12 VDC, Operating current 0.2 to 2.2 AMPS.
24 VDC, Operating current 0.1 to 1.1 AMPS.

SEAL KIT: SKN-1032 Buna "N"

SKV-1032 Viton

INSTALLATION: No restrictions.

WEIGHT: 1.93 lb [0,90 kg] cartridge with coil only.

VALVE CAVITY: #C1030, See Page 0-032.0.

info.el@bucherhydraulics.com

www.bucherhydraulics.com/commoncavity

© 2015 by Bucher Hydraulics, Inc., 2545 Northwest Parkway, Elgin, Illinois 60124, USA

All rights reserved.

The technical information in this catalog, may contain calculated figures (for reference only) and not actual performance data for this product.

Data is provided for the purpose of product description only, and must not be construed as warranted characteristics in the legal sense.

The information does not relieve users from the duty of conducting their own evaluations and tests. Because the products are subject to continual improvement, we reserve the right to amend the product specifications contained in this catalogue.

ELECTRO-HYDRAULIC, PROPORTIONAL, PRIORITY
PRESSURE COMP, FLOW CONTROL VALVE.

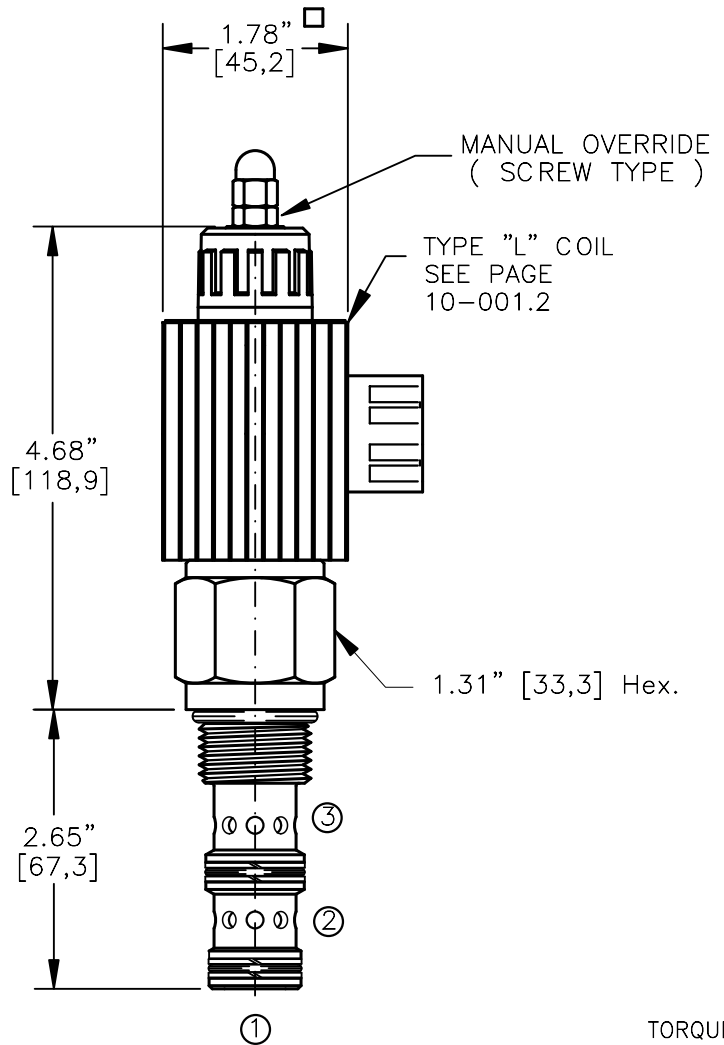
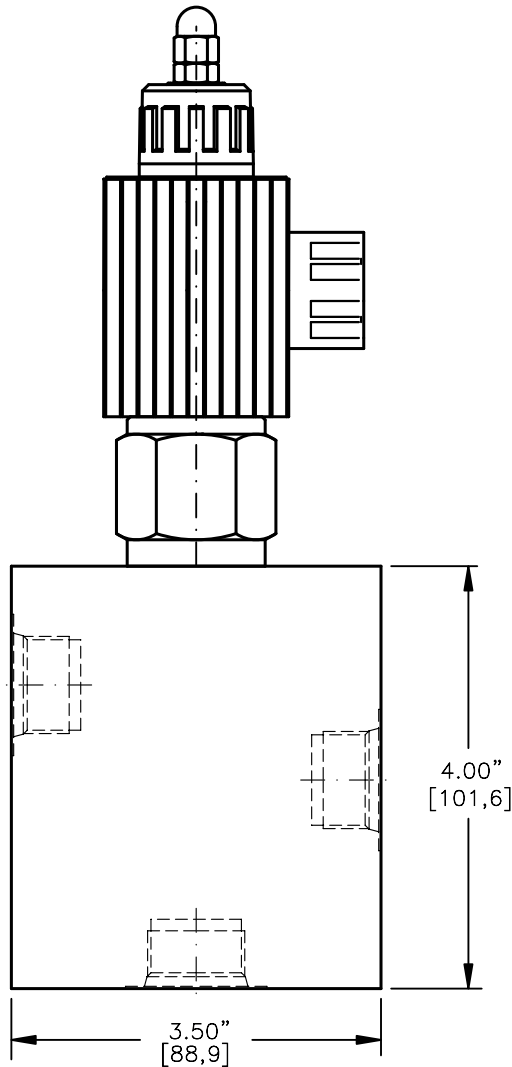
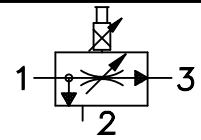

TORQUE
Steel = 75/80 Ft-Lb. [102/109 Nm]
Aluminum = 55/60 Ft-Lb. [74/81 Nm]

EPFB-12-X-X-XX-X-X-XXX X

- BASIC
- SIZE
12 = 1.062"-12UNF
- SEALS
N = BUNA "N"
V = VITON
- STYLE
C = NORMALLY CLOSED
O = NORMALLY OPEN
- REGULATED FLOW
05 = 0 TO 5.0 GPM
10 = 0 TO 10.0 GPM
15 = 0 TO 15.0 GPM
- "A" = ALUM. HOUSING
"S" = STEEL HOUSING
- TERMINALS
L = 18GA. 24" LEADS
T = SPADE TERM.
B = BOLT TERM.
G = DIN43650
W = WEATHER-PACK
D = DEUTSCH-DT04-2P
M = METRI-PACK CONN.
- VOLTAGE AMPS
12D = 12 VDC 3.00
24D = 24 VDC 1.50
- ADJUSTMENT OPTIONS
0 = NONE
M = MANUAL OVERRIDE
- PORTS
0 = CARTRIDGE ONLY
04BX = G 1/2"-14 BSPP
06BX = G 3/4"-14 BSPP
10TX = SAE - #10
12TX = SAE - #12

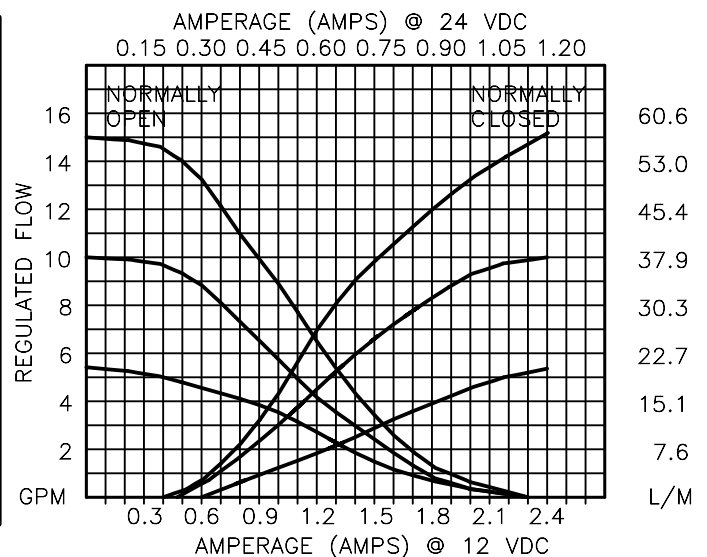

PROPORTIONAL, PRIORITY TYPE, PRESSURE COMP,
FLOW CONTROL VALVE.

DESCRIPTION

This valve is a cartridge style, electro-hydraulic, proportional, priority (BY-PASS) type, pressure compensated, hydraulic flow control. Regulated flow 15.0 GPM [56,8 L/M] max. is proportional to the current input regardless of load or system pressure. After the priority flow is satisfied the excess flow is diverted to a secondary circuit or to tank. Maximum inlet flow is 26.0 GPM [98,4 L/M].

OPERATIONS

This unit is a direct acting (NO PILOT FLOW), electro hydraulic, proportional, pressure compensated, flow control valve. When the coil is energized the armature moves the metering orifice open against a precision bias spring varying the flow. A pressure compensator spool (HYDROSTAT) modulates the flow at 100 PSI/6,9 Bar delta "P" providing the valve with a constant regulated flow regardless of load or system pressure. When current is increased to the coil the flow will increase, as the current is decreased the flow will decrease proportionally. IN THE EVENT OF POWER FAILURE THE VALVE WILL CLOSE.

FEATURES AND BENEFITS

Continuous-duty, very low heat rise & waterproof solenoid coil.
Interchangeable solenoid coils & termination options available.
Hardened precision fitted spool & sleeve provides reliable, long life.
Very efficient wet – armature solenoid core tube construction.
All external carbon steel parts are plated for longer life against the elements.
All cartridge valves are 100% functionally tested.

PROPORTIONAL, PRIORITY TYPE, PRESSURE COMP,
FLOW CONTROL VALVE.

SPECIFICATIONS

OPERATING PRESSURE: 5,000 PSI [350 Bar]

PROOF PRESSURE: 10,000 PSI [700 Bar]

REGULATED FLOW: 15.0 GPM [56,7 l/m] Max. See performance chart.

INTERNAL LEAKAGE: 20 cu.in/min [330 cc/m] @ 5,000 PSI [350 Bar]

VALVE HOUSINGS: 2500 PSI [175 Bar] = Aluminum - Anodized.

5000 PSI [350 Bar] = Steel - Unplated.

OPERATING TEMPERATURE: -40° to +250° F. [-40° to +120° C.]

OPERATING MEDIA: All general purpose hydraulic fluids such as

MIL-H-5606, SAE-#10, SAE-#20, etc.

RESPONSE: The most efficient method to control this valve is with
current control and a 50 Hz dither.

POWER REQUIREMENTS: 12 VDC, Operating current 0.2 to 2.2 AMPS.

24 VDC, Operating current 0.1 to 1.1 AMPS.

SEAL KIT: SKN-1232 Buna "N"

SKV-1232 Viton

INSTALLATION: No restrictions.

WEIGHT: 2.66 lb [1,20 kg] cartridge with coil only.

VALVE CAVITY: #C1230, See Page 0-033.0.

info.el@bucherhydraulics.com

www.bucherhydraulics.com/commoncavity

© 2015 by Bucher Hydraulics, Inc., 2545 Northwest Parkway, Elgin, Illinois 60124, USA

All rights reserved.

The technical information in this catalog, may contain calculated figures (for reference only) and not actual performance data for this product.

Data is provided for the purpose of product description only, and must not be construed as warranted characteristics in the legal sense.

The information does not relieve users from the duty of conducting their own evaluations and tests. Because the products are subject to continual improvement, we reserve the right to amend the product specifications contained in this catalogue.

ELECTRO-HYDRAULIC, PROPORTIONAL, PRIORITY
PRESSURE COMP, FLOW CONTROL VALVE.

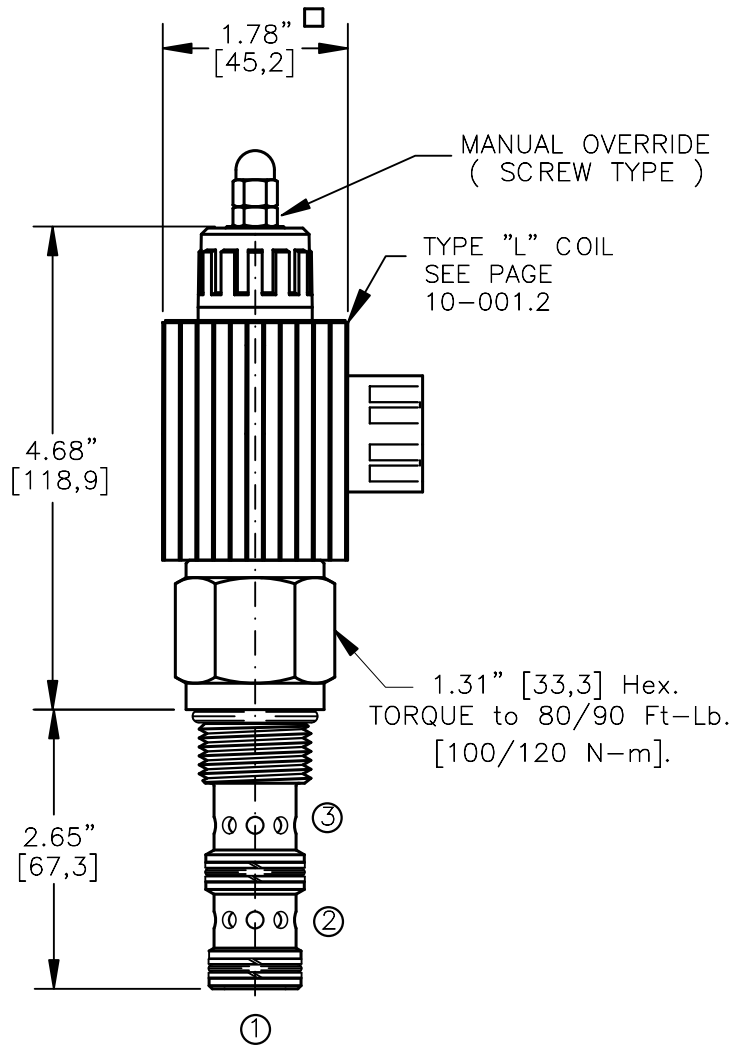
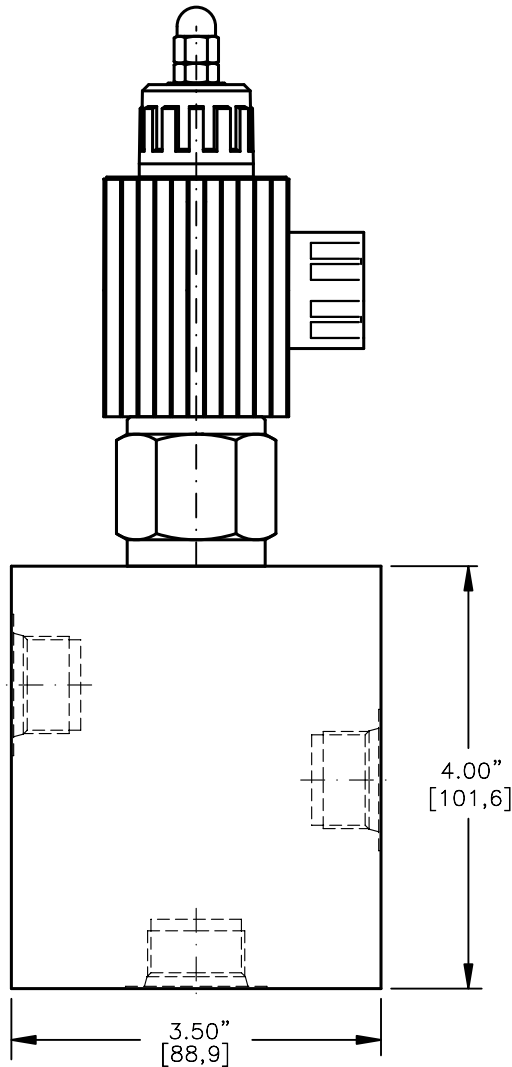
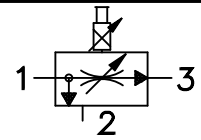

FOR ALUMINUM OR STEEL VALVE HOUSING CONFIGURATIONS SEE PAGE 0-033.1

EPFB-12-X-X-XX-X-X-XXX X

BASIC	TERMINALS
SIZE	L = 18GA. 24" LEADS
12 = 1.062"-12UNF	T = SPADE TERM.
SEALS	B = BOLT TERM.
N = BUNA "N"	G = DIN43650
V = VITON	W = WEATHER-PACK
STYLE	D = DEUTSCH-DT04-2P
C = NORMALLY CLOSED	M = METRI-PACK CONN.
O = NORMALLY OPEN	VOLTAGE AMPS
REGULATED FLOW	12D = 12 VDC 3.00
05 = 0 TO 5.0 GPM	24D = 24 VDC 1.50
10 = 0 TO 10.0 GPM	ADJUSTMENT OPTIONS
15 = 0 TO 15.0 GPM	0 = NONE
PORTS	M = MANUAL OVERRIDE
0 = CARTRIDGE ONLY	
04BX = G 1/2"-14 BSPP	
06BX = G 3/4"-14 BSPP	
10TX = SAE - #10	
12TX = SAE - #12	
"A" = ALUM. HOUSING	
"S" = STEEL HOUSING	

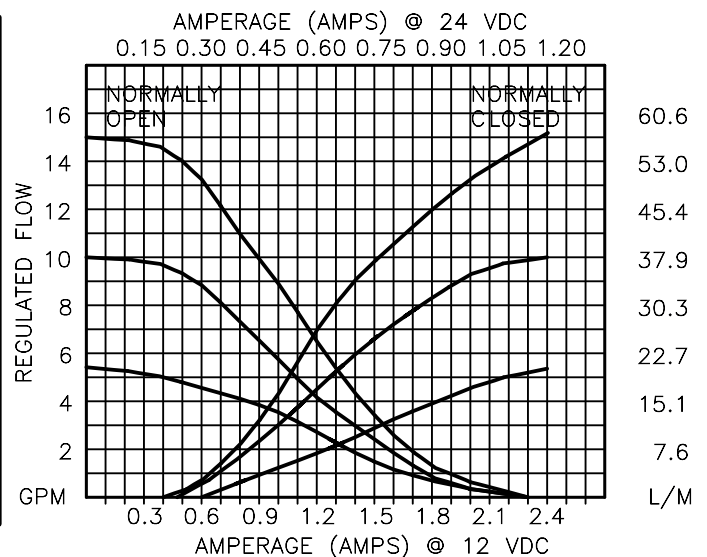

**PROPORTIONAL, PRIORITY TYPE, PRESSURE COMP,
FLOW CONTROL VALVE.****DESCRIPTION**

This valve is a cartridge style, electro-hydraulic, proportional, priority (BY-PASS) type, pressure compensated, hydraulic flow control. Regulated flow 15.0 GPM [56,8 L/M] max. is proportional to the current input regardless of load or system pressure. After the priority flow is satisfied the excess flow is diverted to a secondary circuit or to tank. Maximum inlet flow is 26.0 GPM [98,4 L/M].

OPERATIONS

This unit is a direct acting (NO PILOT FLOW), electro hydraulic, proportional, pressure compensated, flow control valve. When the coil is energized the armature moves the metering orifice open against a precision bias spring varying the flow. A pressure compensator spool (HYDROSTAT) modulates the flow at 100 PSI/6,9 Bar delta "P" providing the valve with a constant regulated flow regardless of load or system pressure. When current is increased to the coil the flow will increase, as the current is decreased the flow will decrease proportionally. IN THE EVENT OF POWER FAILURE THE VALVE WILL CLOSE.

FEATURES AND BENEFITS

Continuous-duty, very low heat rise & waterproof solenoid coil.
Interchangeable solenoid coils & termination options available.
Hardened precision fitted spool & sleeve provides reliable, long life.
Very efficient wet – armature solenoid core tube construction.
All external carbon steel parts are plated for longer life against the elements.
All cartridge valves are 100% functionally tested.

PROPORTIONAL, PRIORITY TYPE, PRESSURE COMP,
FLOW CONTROL VALVE.

SPECIFICATIONS

OPERATING PRESSURE: 5,000 PSI [350 Bar]

PROOF PRESSURE: 10,000 PSI [700 Bar]

REGULATED FLOW: 15.0 GPM [56,7 l/m] Max. See performance chart.

INTERNAL LEAKAGE: 20 cu.in/min [330 cc/m] @ 5,000 PSI [350 Bar]

VALVE HOUSINGS: 2500 PSI [175 Bar] = Aluminum - Anodized.

5000 PSI [350 Bar] = Steel - Unplated.

OPERATING TEMPERATURE: -40° to +250° F. [-40° to +120° C.]

OPERATING MEDIA: All general purpose hydraulic fluids such as

MIL-H-5606, SAE-#10, SAE-#20, etc.

RESPONSE: The most efficient method to control this valve is with
current control and a 50 Hz dither.

POWER REQUIREMENTS: 12 VDC, Operating current 0.2 to 2.2 AMPS.

24 VDC, Operating current 0.1 to 1.1 AMPS.

SEAL KIT: SKN-1232 Buna "N"

SKV-1232 Viton

INSTALLATION: No restrictions.

WEIGHT: 2.66 lb [1,20 kg] cartridge with coil only.

VALVE CAVITY: #C1230, See Page 0-033.0.

info.el@bucherhydraulics.com

www.bucherhydraulics.com/commoncavity

© 2015 by Bucher Hydraulics, Inc., 2545 Northwest Parkway, Elgin, Illinois 60124, USA

All rights reserved.

The technical information in this catalog, may contain calculated figures (for reference only) and not actual performance data for this product.

Data is provided for the purpose of product description only, and must not be construed as warranted characteristics in the legal sense.

The information does not relieve users from the duty of conducting their own evaluations and tests. Because the products are subject to continual improvement, we reserve the right to amend the product specifications contained in this catalogue.

ELECTRO-HYDRAULIC, PROPORTIONAL, PRIORITY,
PRESSURE COMP, FLOW CONTROL VALVE.

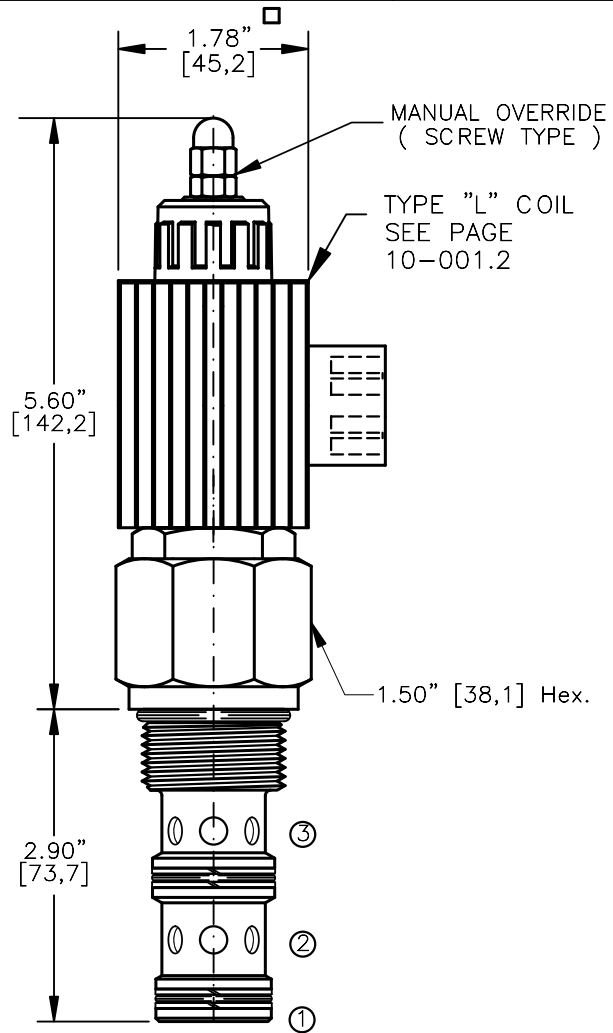
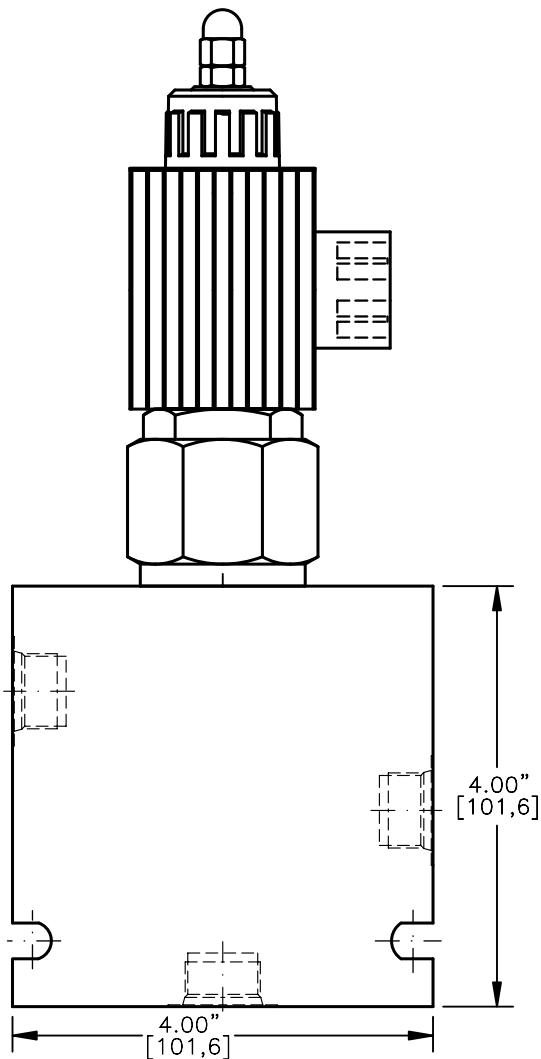
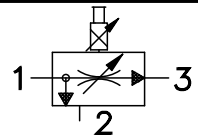

TORQUE:

Steel = 95/100 Ft-Lb. [129/136 Nm]
Aluminum = 70/75 Ft-Lb. [95/102 Nm]

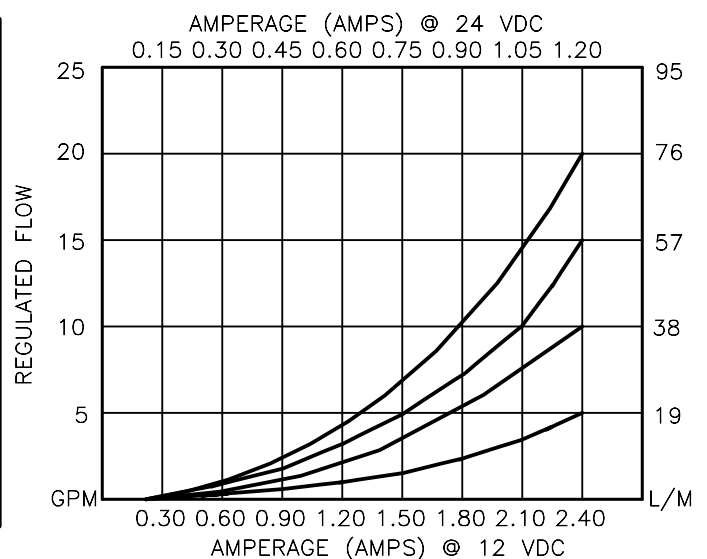
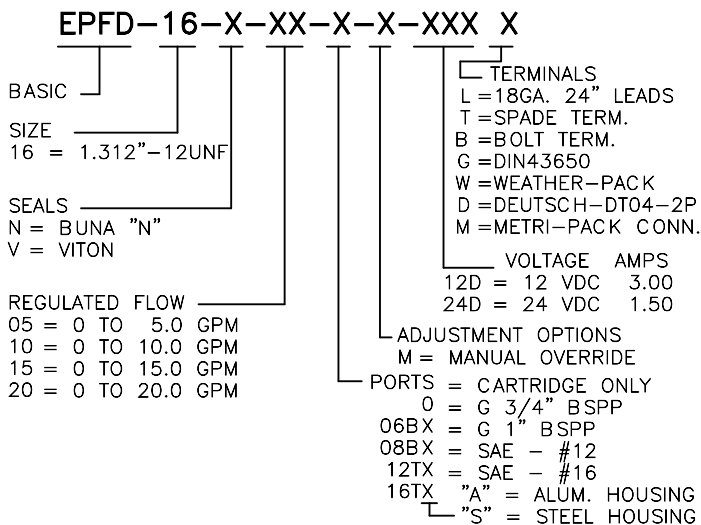

PROPORTIONAL, PRIORITY TYPE, PRESSURE COMP,
FLOW CONTROL VALVE.

DESCRIPTION

This valve is a cartridge style, electro-hydraulic, proportional, priority (BY-PASS) type, pressure compensated, hydraulic flow control. Regulated flow 20.0 GPM [76,0 L/M] max. is proportional to the current input regardless of load or system pressure. After the priority flow is satisfied the excess flow is diverted to a secondary circuit or to tank. Maximum inlet flow is 35.0 GPM [130,0 L/M].

OPERATIONS

This unit is a direct acting (NO PILOT FLOW), electro hydraulic, proportional, pressure compensated, flow control valve. When the coil is energized the armature moves the metering orifice open against a precision bias spring varying the flow. A pressure compensator spool (HYDROSTAT) modulates the flow at 100 PSI/6,9 Bar delta "P" providing the valve with a constant regulated flow regardless of load or system pressure. When current is increased to the coil the flow will increase, as the current is decreased the flow will decrease proportionally. IN THE EVENT OF POWER FAILURE THE VALVE WILL CLOSE.

FEATURES AND BENEFITS

Continuous-duty, very low heat rise & waterproof solenoid coil.
Interchangeable solenoid coils & terminations options available.
Hardened precision fitted spool & sleeve provides reliable, long life.
Very efficient wet – armature solenoid core tube construction.
All external carbon steel parts are plated for longer life against the elements.
All cartridge valves are 100% functionally tested.

PROPORTIONAL, PRIORITY TYPE, PRESSURE COMP,
FLOW CONTROL VALVE.

SPECIFICATIONS

OPERATING PRESSURE: 5,000 PSI [350 Bar]

PROOF PRESSURE: 10,000 PSI [700 Bar]

REGULATED FLOW: 20.0 GPM [76,0 l/m] Max. See performance chart.

INTERNAL LEAKAGE: 20 cu.in./min [330 cc/m] @ 5,000 PSI [350 Bar]

VALVE HOUSINGS: 2500 PSI [175 Bar] = Aluminum – Anodized.

5000 PSI [350 Bar] = Steel – Unplated.

OPERATING TEMPERATURE: -40° to +250° F. [-40° to +120° C.]

OPERATING MEDIA: All general purpose hydraulic fluids such as

MIL-H-5606, SAE-#10, SAE-#20, etc.

RESPONSE: The most efficient method to control this valve is with
current control and a 50 Hz dither.

POWER REQUIREMENTS: 12 VDC, Operating current 0.2 to 2.2 AMPS.

24 VDC, Operating current 0.1 to 1.1 AMPS.

SEAL KIT: SKN-1632 Buna "N"

SKV-1632 Viton

INSTALLATION: No restrictions.

WEIGHT: 2.66 lb [1,20 kg] cartridge with coil only.

VALVE CAVITY: #C1630, See Page 0-034.0.

info.el@bucherhydraulics.com

www.bucherhydraulics.com/commoncavity

© 2015 by Bucher Hydraulics, Inc., 2545 Northwest Parkway, Elgin, Illinois 60124, USA

All rights reserved.

The technical information in this catalog, may contain calculated figures (for reference only) and not actual performance data for this product.

Data is provided for the purpose of product description only, and must not be construed as warranted characteristics in the legal sense.

The information does not relieve users from the duty of conducting their own evaluations and tests. Because the products are subject to continual improvement, we reserve the right to amend the product specifications contained in this catalogue.

PROPORTIONAL, NORMALLY CLOSED OR NORMALLY OPEN,
IN-LINE, NON-COMPENSATED FLOW CONTROL VALVE.

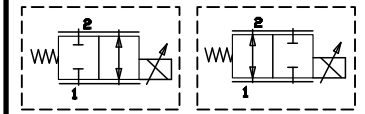

UL approved coil, IP68 and IP69K rated when used with waterproof connector.

TORQUE:

Steel = 55/60 Ft-Lb. [74/81 Nm]
Aluminum = 35/40 Ft-Lb. [47/54 Nm]

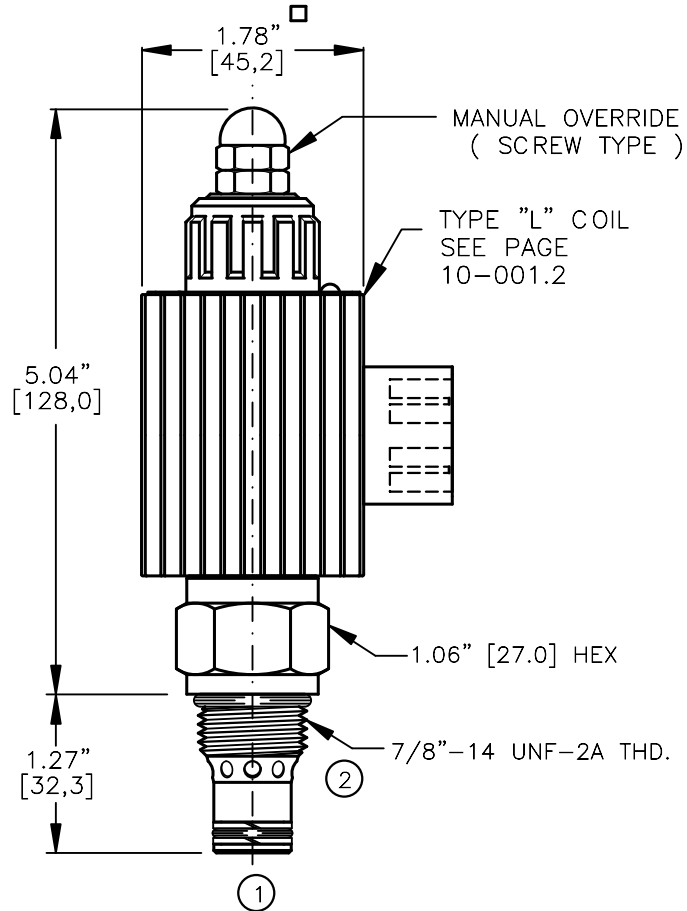
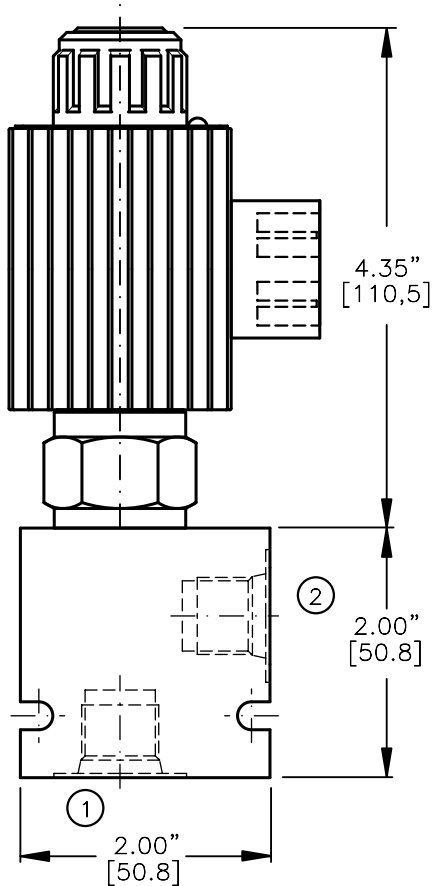

NOTES:

- FOR ALUMINUM OR STEEL VALVE HOUSING CONFIGURATIONS SEE PAGE 0-012.1
- SOLENOIDS AVAILABLE WITH DIODES - CONSULT FACTORY.

PFCV-10-X-X-XX-X-X-XXX X

BASIC
SIZE
10 = 7/8"-14UNF

SEALS
N = BUNA "N"
V = VITON

STYLE
C = NORMALLY CLOSED
O = NORMALLY OPEN

REGULATED FLOW
04 = 0 TO 4.0 GPM
08 = 0 TO 8.0 GPM
12 = 0 TO 12.0 GPM
16 = 0 TO 16.0 GPM

"A" = ALUM. HOUSING
"S" = STEEL HOUSING

TERMINALS
L = 18GA. 24" LEADS
T = SPADE TERM.
B = BOLT TERM.
G = DIN43650
W = WEATHER-PACK
D = DEUTSCH-DT04-2P
M = METRI-PACK CONN.

VOLTAGE AMPS
12D = 12 VDC 3.00
24D = 24 VDC 1.50

ADJUSTMENT OPTIONS
O = NONE
M = MANUAL OVERRIDE

PORTS
0 = CARTRIDGE ONLY
02BX = G 1/4" BSPP
03BX = G 3/8" BSPP
06TX = SAE - #6
08TX = SAE - #8

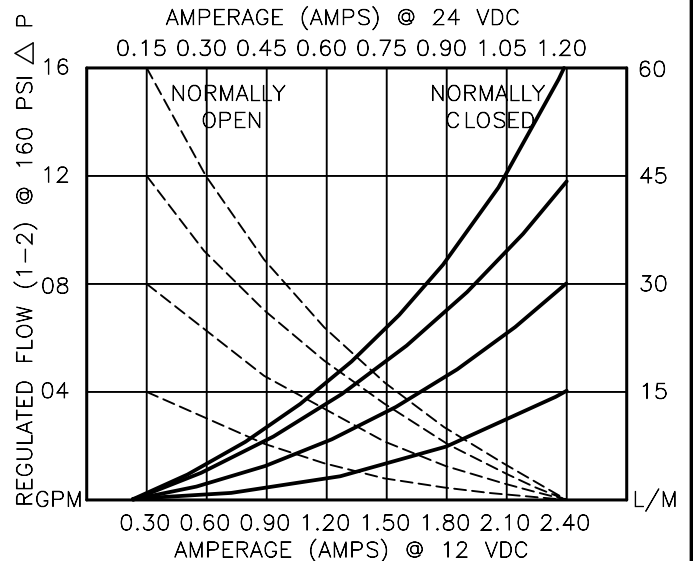

PROPORTIONAL, IN-LINE TYPE, FLOW CONTROL VALVE.**DESCRIPTION**

This valve is a cartridge style, electro-hydraulic, proportional, in-line (RESTRICTIVE) type, hydraulic non-compensated flow control. Regulated flow Normally Closed 0 to 16.0 GPM [0 to 61,0 L/m] max. Normally Open 16.0 to 0 GPM [61,0 to 0 L/m] @ 160 PSI DELTA P. Flow is proportional to the current input.

OPERATIONS

This unit is a direct acting (NO PILOT FLOW), electro hydraulic, proportional, non-compensated, flow control valve. When the coil is energized the armature moves the metering orifice to open or to closed position against a precision bias spring varying the flow.

When current is increased or decreased to the coil, the flow will increase or decrease proportionally.

IN THE EVENT OF POWER FAILURE THE VALVE WILL CLOSE OR OPEN DEPENDING ON THE VALVE VERSION.

FEATURES AND BENEFITS

Continuous-duty, very low heat rise & waterproof solenoid coil.

Interchangeable solenoid coils & termination options available.

Hardened precision fitted spool & sleeve provides reliable, long life.

Very efficient wet – armature solenoid core tube construction.

All external carbon steel parts are plated for longer life against the elements.

All cartridge valves are 100% functionally tested.

Industry common cavity.

PROPORTIONAL, IN-LINE TYPE, FLOW CONTROL VALVE.**SPECIFICATIONS**

OPERATING PRESSURE: 5,000 PSI [350 Bar]

PROOF PRESSURE: 10,000 PSI [700 Bar]

REGULATED FLOW: 16.0 GPM [61,0 L/m] Max. See performance chart.

INTERNAL LEAKAGE: 20 cu.in/min [330 cc/m] @ 160 PSI DELTA P [11 Bar]

VALVE HOUSINGS: 2500 PSI [175 Bar] = Aluminum – Anodized.

5000 PSI [350 Bar] = Steel – Unplated.

OPERATING TEMPERATURE: -40° to +250° F. [-40° to +120° C.]

OPERATING MEDIA: All general purpose hydraulic fluids such as

MIL-H-5606, SAE-#10, SAE-#20, etc.

RESPONSE: The most efficient method to control this valve is with
current control and a 50 Hz dither.

POWER REQUIREMENTS: 12 VDC, Operating current 0.4 to 2.4 AMPS.

24 VDC, Operating current 0.2 to 1.2 AMPS.

SEAL KIT: SKN-1022 Buna "N"

SKV-1022 Viton

INSTALLATION: Flow 1-2 preferred, Max Flow 2-1 lower than shown on
graph. Use undercuts in cavity to obtain max rated flow when using a
pressure compensator in series. Pressure drop across valve must not
exceed 300 PSI [21] bar.

WEIGHT: 0.74 lbs [0,34 kg] cartridge only.

1.09 lbs [0,50 kg] coil & housing.

0.35 lbs [0,16 kg] aluminum body.

1.20 lbs [0,54 kg] steel body.

VALVE CAVITY: #C 1020, See Page 0-012.0.

info.el@bucherhydraulics.com

www.bucherhydraulics.com/commoncavity

© 2015 by Bucher Hydraulics, Inc., 2545 Northwest Parkway, Elgin, Illinois 60124, USA

All rights reserved.

The technical information in this catalog, may contain calculated figures (for reference only) and not actual performance data for this product.

Data is provided for the purpose of product description only, and must not be construed as warranted characteristics in the legal sense.

The information does not relieve users from the duty of conducting their own evaluations and tests. Because the products are subject to continual improvement, we reserve the right to amend the product specifications contained in this catalogue.

PROPORTIONAL, NORMALLY CLOSED OR NORMALLY OPEN,
IN-LINE, NON-COMPENSATED FLOW CONTROL VALVE.

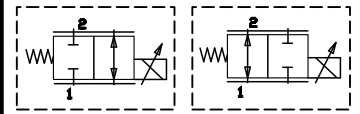

UL approved coil, IP68 and IP69K rated when used with waterproof connector.

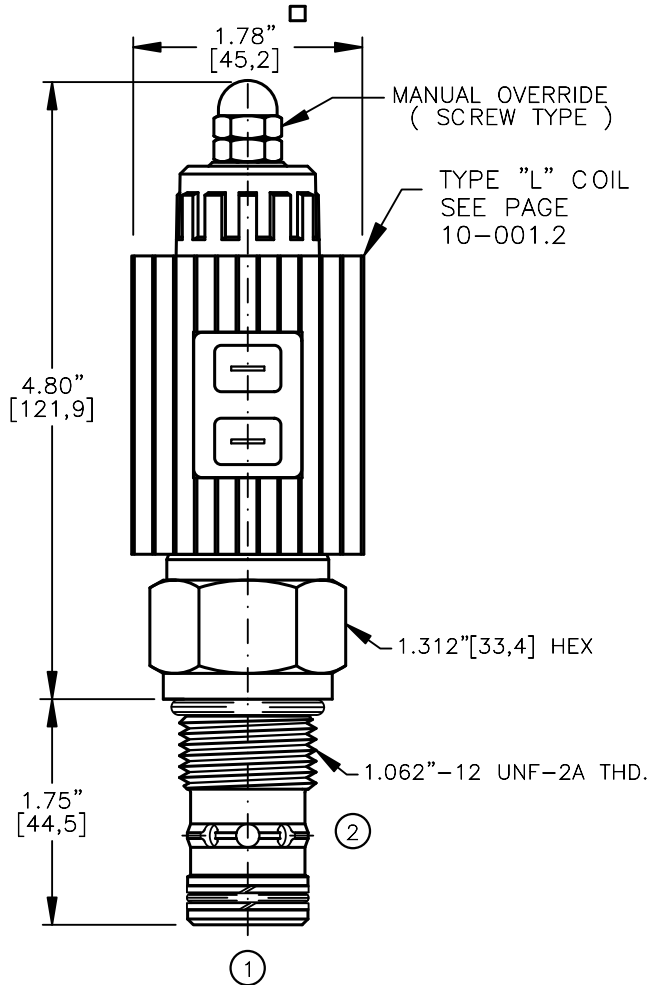
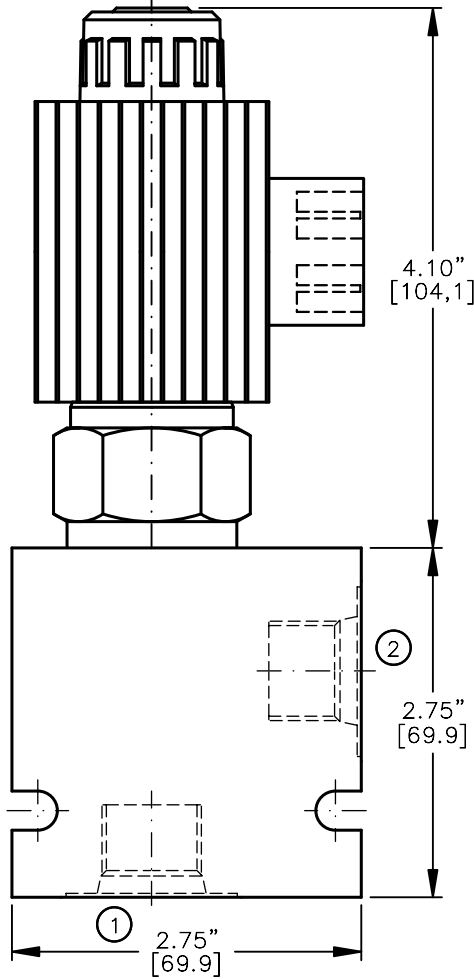

TORQUE:
Steel = 70/75 Ft-Lb. [95/102 Nm]
Aluminum = 55/60 Ft-Lb. [74/81 Nm]

PFCV-12-X-X-XX-X-X-XXX X

- BASIC
- SIZE
12 = 1.062"-12UNF
- SEALS
N = BUNA "N"
V = VITON
- STYLE
C = NORMALLY CLOSED
O = NORMALLY OPEN
- REGULATED FLOW
06 = 0 TO 6.0 GPM
12 = 0 TO 12.0 GPM
18 = 0 TO 18.0 GPM
24 = 0 TO 24.0 GPM
- "A" = ALUM. HOUSING
"S" = STEEL HOUSING
- TERMINALS
L = 18GA. 24" LEADS
T = SPADE TERM.
B = BOLT TERM.
G = DIN43650
W = WEATHER-PACK
D = DEUTSCH-DT04-2P
M = METRI-PACK CONN.
- VOLTAGE AMPS
12D = 12 VDC 3.00
24D = 24 VDC 1.50
- ADJUSTMENT OPTIONS
O = NONE
M = MANUAL OVERRIDE
- PORTS
O = CARTRIDGE ONLY
04BX = G 1/2" BSPP
06BX = G 3/4" BSPP
10TX = SAE - #10
12TX = SAE - #12

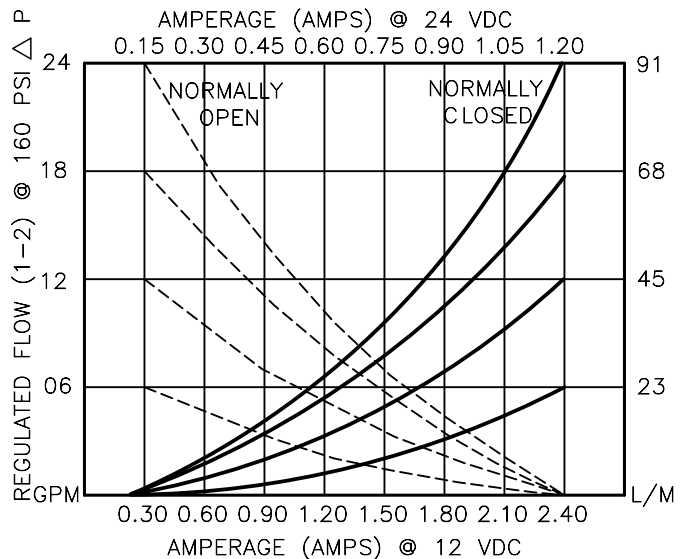

PROPORTIONAL, IN-LINE TYPE, FLOW CONTROL VALVE.**DESCRIPTION**

This valve is a cartridge style, electro-hydraulic, proportional, in-line (RESTRICTIVE) type, hydraulic non-compensated flow control. Regulated flow Normally Closed 0 to 24.0 GPM [0 to 91,2 L/M] max. Normally Open 24.0 to 0 GPM [91,2 to 0 L/m] @ 160 PSI DELTA P. Flow is proportional to the current input.

OPERATIONS

This unit is a direct acting (NO PILOT FLOW), electro-hydraulic, proportional, non-compensated, flow control valve. When the coil is energized the armature moves the metering orifice to open or to closed position against a precision bias spring varying the flow.

When current is increased or decreased to the coil the flow will increase or decrease proportionally.

IN THE EVENT OF POWER FAILURE THE VALVE WILL CLOSE OR OPEN DEPENDING ON THE VALVE VERSION.

FEATURES AND BENEFITS

Continuous-duty, very low heat rise & waterproof solenoid coil.

Interchangeable solenoid coils & terminations options available.

Hardened precision fitted spool & sleeve provides reliable, long life.

Very efficient wet – armature solenoid core tube construction.

All external carbon steel parts are plated for longer life against the elements.

All cartridge valves are 100% functionally tested.

PROPORTIONAL, IN-LINE TYPE, FLOW CONTROL VALVE.**SPECIFICATIONS**

OPERATING PRESSURE: 5,000 PSI [350 Bar]

PROOF PRESSURE: 10,000 PSI [700 Bar]

REGULATED FLOW: 25.0 GPM [94,5 l/m] Max. See performance chart.

INTERNAL LEAKAGE: 30 cu.in/min [495 cc/m] @ 160 PSI DELTA P [11 Bar]

VALVE HOUSINGS: 2500 PSI [175 Bar] = Aluminum - Anodized.

5000 PSI [350 Bar] = Steel - Unplated.

OPERATING TEMPERATURE: -40° to +250° F. [-40° to +120° C.]

OPERATING MEDIA: All general purpose hydraulic fluids such as

MIL-H-5606, SAE-#10, SAE-#20, etc.

RESPONSE: The most efficient method to control this valve is with current control and a 50 Hz dither.

POWER REQUIREMENTS: 12 VDC, Operating current 0.4 to 2.4 AMPS.

24 VDC, Operating current 0.2 to 1.2 AMPS.

SEAL KIT: SKN-1222 Buna "N"

SKV-1222 Viton

INSTALLATION: Flow 1-2 preferred, Max Flow 2-1 lower than shown on graph. Use undercuts in cavity to obtain max rated flow when using a pressure compensator in series. Pressure drop across valve must not exceed 300 PSI [21] bar.

WEIGHT: 0.84 lbs [0,38 kg] cartridge only.

1.09 lbs [0,50 kg] coil & housing.

1.10 lbs [0,50 kg] aluminum body.

4.20 lbs [1,90 kg] steel body.

VALVE CAVITY: #C1220, See Page 0-013.0.

info.el@bucherhydraulics.com

www.bucherhydraulics.com/commoncavity

© 2015 by Bucher Hydraulics, Inc., 2545 Northwest Parkway, Elgin, Illinois 60124, USA

All rights reserved.

The technical information in this catalog, may contain calculated figures (for reference only) and not actual performance data for this product.

Data is provided for the purpose of product description only, and must not be construed as warranted characteristics in the legal sense.

The information does not relieve users from the duty of conducting their own evaluations and tests. Because the products are subject to continual improvement, we reserve the right to amend the product specifications contained in this catalogue.

PROPORTIONAL, NORMALLY CLOSED OR NORMALLY OPEN,
IN-LINE, NON-COMPENSATED FLOW CONTROL VALVE.

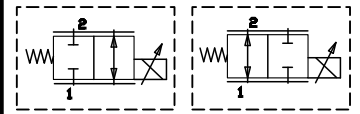

UL approved coil, IP68 and IP69K rated when used with waterproof connector.

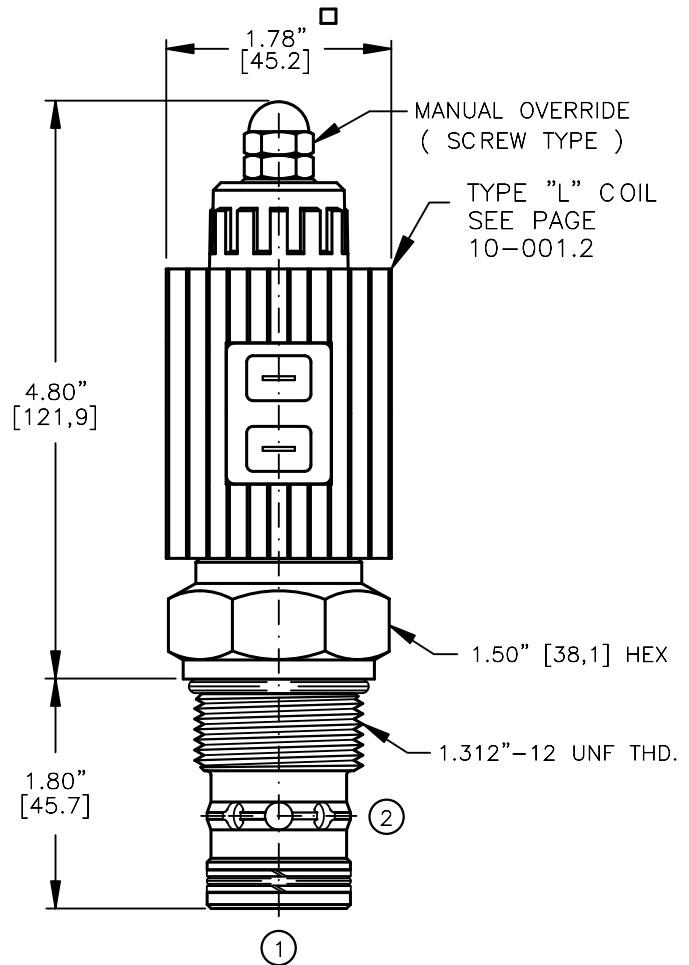
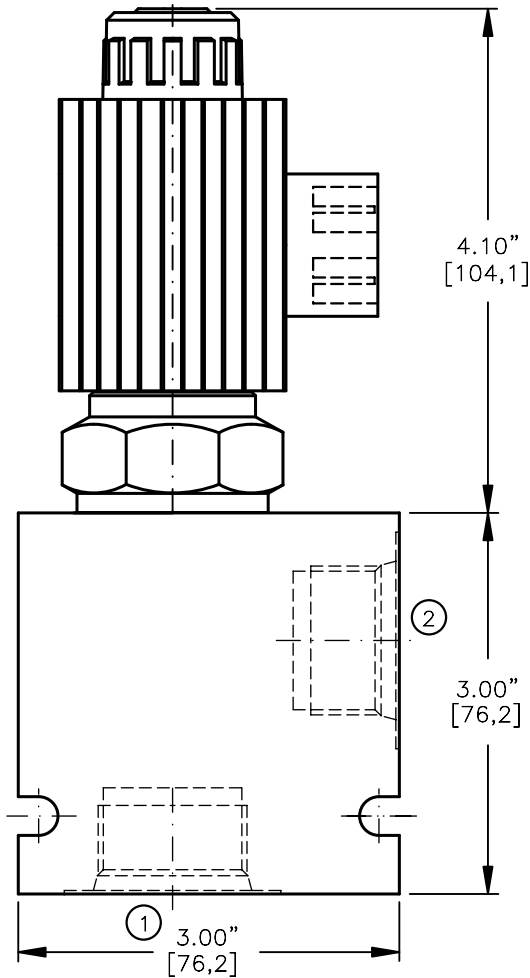

TORQUE:

Steel = 95/100 Ft-Lb. [129/136 Nm]
Aluminum = 70/75 Ft-Lb. [95/102 Nm]

PFCV-16-X-X-XX-X-X-XXX X

BASIC
SIZE
16 = 1.312"-12UNF

SEALS
N = BUNA "N"
V = VITON

STYLE
C = NORMALLY CLOSED
O = NORMALLY OPEN

REGULATED FLOW
06 = 0 TO 6.0 GPM
12 = 0 TO 12.0 GPM
18 = 0 TO 18.0 GPM
24 = 0 TO 24.0 GPM
30 = 0 TO 30.0 GPM

"A" = ALUM. HOUSING
"S" = STEEL HOUSING

TERMINALS
L = 18GA. 24" LEADS
T = SPADE TERM.
B = BOLT TERM.
G = DIN43650
W = WEATHER-PACK
D = DEUTSCH-DT04-2P
M = METRI-PACK CONN.

VOLTAGE AMPS
12D = 12 VDC 3.00
24D = 24 VDC 1.50

ADJUSTMENT OPTIONS
O = NONE
M = MANUAL OVERRIDE

PORTS
O = CARTRIDGE ONLY
06BX = G 3/4" BSPP
08BX = G 1" BSPP
12TX = SAE - #12
16TX = SAE - #16

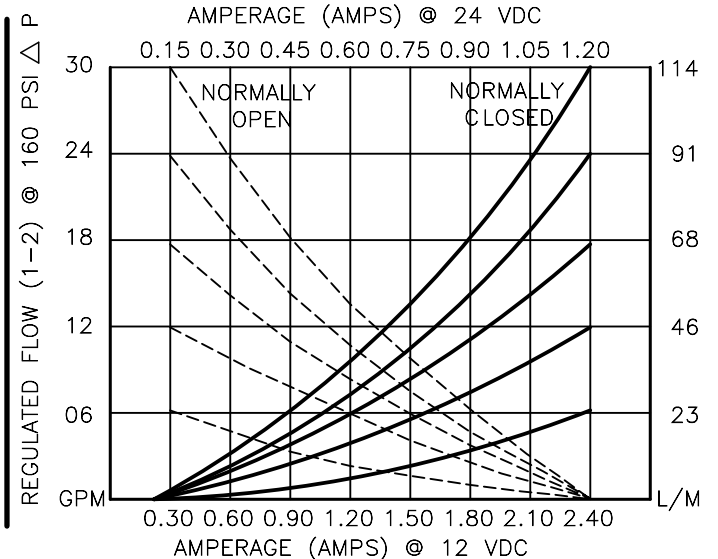

PROPORTIONAL, IN-LINE TYPE, FLOW CONTROL VALVE.**DESCRIPTION**

This valve is a cartridge style, electro-hydraulic, proportional, in-line (RESTRICTIVE) type, hydraulic non-compensated flow control. Regulated flow Normally Closed 0 to 36.0 GPM [0 to 137,0 L/M] max. Normally Open 36.0 to 0 GPM [137,0 to 0 L/m] @ 160 PSI DELTA P. Flow is proportional to the current input.

OPERATIONS

This unit is a direct acting (NO PILOT FLOW), electro-hydraulic, proportional, non-compensated, flow control valve. When the coil is energized the armature moves the metering orifice to open or to closed position against a precision bias spring varying the flow.

When current is increased or decreased to the coil the flow will increase or decrease proportionally.

IN THE EVENT OF POWER FAILURE THE VALVE WILL CLOSE OR OPEN DEPENDING ON THE VALVE VERSION.

FEATURES AND BENEFITS

Continuous-duty, very low heat rise & waterproof solenoid coil.

Interchangeable solenoid coils & terminations options available.

Hardened precision fitted spool & sleeve provides reliable, long life.

Very efficient wet – armature solenoid core tube construction.

All external carbon steel parts are plated for longer life against the elements.

All cartridge valves are 100% functionally tested.

Industry common cavity.

PROPORTIONAL, IN-LINE TYPE, FLOW CONTROL VALVE.**SPECIFICATIONS**

OPERATING PRESSURE: 5,000 PSI [350 Bar]

PROOF PRESSURE: 10,000 PSI [700 Bar]

REGULATED FLOW: 36.0 GPM [136,0 l/m] Max. See performance chart.

INTERNAL LEAKAGE: 40 cu.in/min [660 cc/m] @ 160 PSI DELTA P [11 Bar]

VALVE HOUSINGS: 2500 PSI [175 Bar] = Aluminum - Anodized.

5000 PSI [350 Bar] = Steel - Unplated.

OPERATING TEMPERATURE: -40° to +250° F. [-40° to +120° C.]

OPERATING MEDIA: All general purpose hydraulic fluids such as

MIL-H-5606, SAE-#10, SAE-#20, etc.

RESPONSE: The most efficient method to control this valve is with
current control and a 50 Hz dither.

POWER REQUIREMENTS: 12 VDC, Operating current 0.4 to 2.4 AMPS.

24 VDC, Operating current 0.2 to 1.2 AMPS.

SEAL KIT: SKN-1622 Buna "N"

SKV-1622 Viton

INSTALLATION: Flow 1-2 preferred, Max Flow 2-1 lower than shown on
graph. Use undercuts in cavity to obtain max rated flow when using a
pressure compensator in series. Pressure drop across valve must not
exceed 300 PSI [21] bar.

WEIGHT: 0.95 lbs [0,42 kg] cartridge only.

1.09 lbs [0,50 kg] coil & housing.

1.25 lbs [0,57 kg] aluminum body.

4.65 lbs [2,10 kg] steel body.

VALVE CAVITY: #C 1620, See Page 0-014.0.

info.el@bucherhydraulics.comwww.bucherhydraulics.com/commoncavity

© 2015 by Bucher Hydraulics, Inc., 2545 Northwest Parkway, Elgin, Illinois 60124, USA

All rights reserved.

The technical information in this catalog, may contain calculated figures (for reference only) and not actual performance data for this product.

Data is provided for the purpose of product description only, and must not be construed as warranted characteristics in the legal sense.

The information does not relieve users from the duty of conducting their own evaluations and tests. Because the products are subject to continual improvement, we reserve the right to amend the product specifications contained in this catalogue.

Proportional 3/2 Throttle Cartridge, Size 5

$Q_{\max} = 30 \text{ l/min}$, $p_{\max} = 250 \text{ bar}$
Sliding-spool design, direct acting
Series MDR32GN...-5...

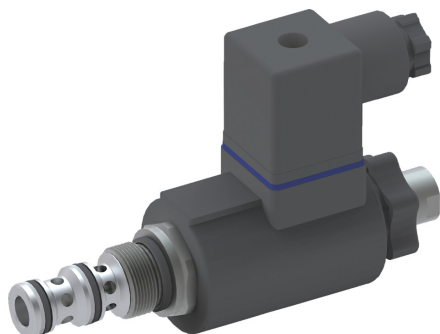

- De-energised closed 1 → 2
- Compact construction for cavity type AM – 3/4-16 UNF
- Very good reproducibility
- Reliable operation over the whole pressure and flow range (even with high pressure differentials)
- With optional manual flow setting
- All exposed parts with zinc-nickel plating
- High pressure wet-armature solenoids
- The slip-on coil can be rotated, and it can be replaced without opening the hydraulic envelope
- Various plug-connector systems and voltages are available
- Can be fitted in a line-mounting body

1 Description

Series MDR32GN... direct acting proportional 3/2 throttle valves are size 5, high performance screw-in cartridges with a 3/4-16 UNF mounting thread. They are designed on the proven sliding-spool principle. The straightforward design delivers an outstanding price/performance ratio. In the initial position (de-energised), port 1 is closed and ports 2 → 3 are connected with the full flow rating. In control mode, the flow through the connection 1 → 2 is varied in proportionally to the control current. Three types are available: Type "A" - standard model, for general use with or without compensator. Type "Z" - special model, only approved for use with compensator (max. Δp 15 bar). Type "S600" - special model with optimised characteristic - $Q = f(I)$, also only

suitable for use with compensator. With this model, the connection 2 → 3 is only used for unloading (see Performance Graphs). These cartridges are particularly suitable for precise and controlled lifting and lowering movements, but they can also be used for reliable operation in mobile and industrial applications featuring large pressure differences. All external parts of the cartridge are zinc-nickel plated to DIN 50 979 and are thus suitable for use in the harshest operating environments. The slip-on coils can be replaced without opening the hydraulic envelope and can be positioned at any angle through 360°. If you intend to manufacture your own cavities or are designing a line-mounting installation, please refer to the section "Related data sheets".

2 Symbol



MDR32GNA5...
MDR32GNZ5...

MDR32GNA5...S600

3 Technical data

General characteristics	Description, value, unit
Designation	proportional 3/2 throttle cartridge
Design	sliding-spool design, direct acting
Mounting method	screw-in cartridge 3/4-16 UNF
Tightening torque	40 Nm ± 10 %

General characteristics	Description, value, unit
Size	nominal size 5, cavity type AM
Weight	0.40 kg
Mounting attitude	unrestricted (preferably vertical, coil down)
Ambient temperature range	-25 °C ... +50 °C

Hydraulic characteristics	Description, value, unit
Maximum operating pressure	250 bar
Maximum flow rate	30 l/min
Nominal flow rate 1 → 2	25 l/min at $\Delta p = 10$ bar
Leakage flow rate	< 150 cm ³ /min (with p_N 250 bar) with oil viscosity 33 mm ² /s (cSt)
Flow direction	see symbols
Hydraulic fluid	HL and HLP mineral oil to DIN 51 524; for other fluids, please contact BUCHER
Hydraulic fluid temperature range	-25 °C ... +70 °C
Viscosity range	15...380 mm ² /s (cSt), recommended 20...130 mm ² /s (cSt)
Minimum fluid cleanliness Cleanliness class to ISO 4406 : 1999	class 18/16/13

Electrical characteristics	Description, value, unit
Supply voltage	12 V DC, 24 V DC
Control current	12 V = 0...1400 mA, 24 V = 0...760 mA
Power consumption at max. control current	max. 19 W
Coil resistance R - cold value at 20 °C - max. warm value	12 V = 5.8 Ω / 24 V = 21 Ω 12 V = 8.6 Ω / 24 V = 32 Ω
Recommended PWM frequency (dither)	200 Hz
Hysteresis with PWM	2...4 % I_N
Reversal error with PWM	2...4 % I_N
Sensitivity with PWM	< 1 % I_N
Reproducibility with PWM	< 2 % p_N
Relative duty cycle	100 %
Protection class to ISO 20 653 / EN 60 529	IP 65 / IP 67 / IP 69K, see "Ordering code" (with appropriate mating connector and proper fitting and sealing)
Electrical connection	3-pin square plug to ISO 4400 / DIN 43 650 (standard) for other connectors, see "Ordering code"

4 Performance graphs measured with oil viscosity 33 mm²/s (cSt)

For general use with / without compensator – type “A”

$\Delta p = f(Q)$ Pressure drop - Flow rate characteristic

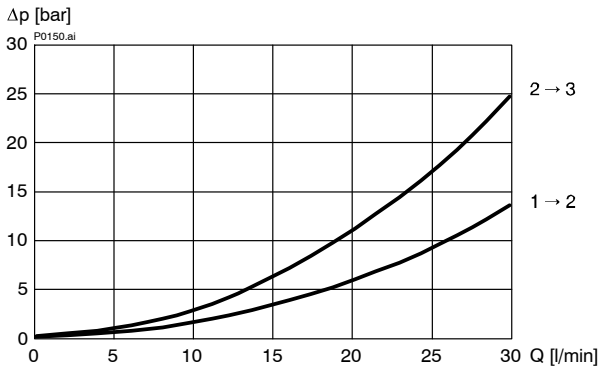

$Q = f(I; \Delta p)$ Flow rate adjustment characteristic

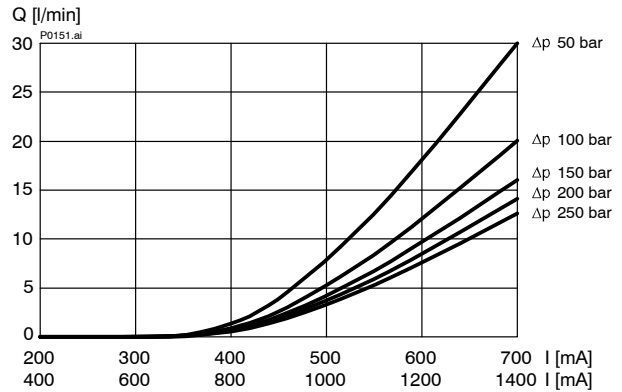

For use with compensator (max. $\Delta p = 15$ bar) – type “Z”

$\Delta p = f(Q)$ Pressure drop - Flow rate characteristic

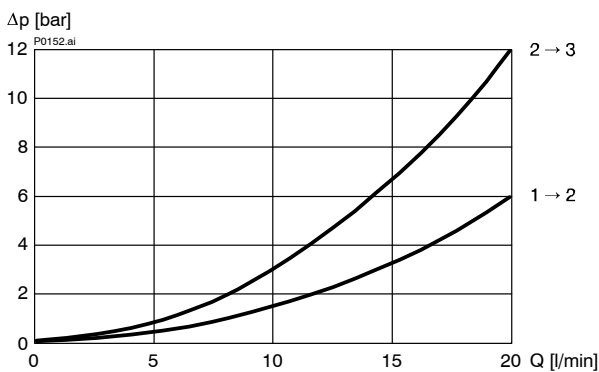

$Q = f(I; \Delta p)$ Flow rate adjustment characteristic

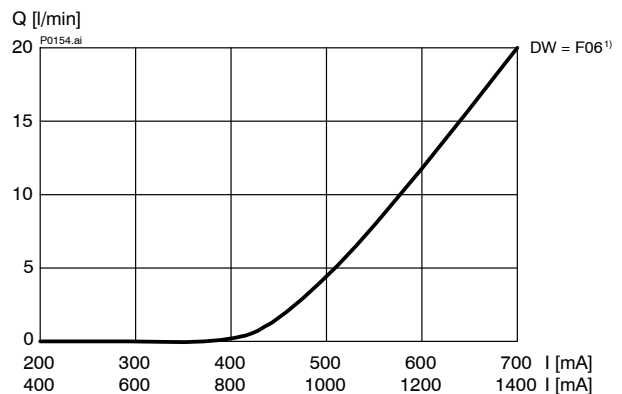

$Q = f(\Delta p; I)$ Flow rate adjustment characteristic

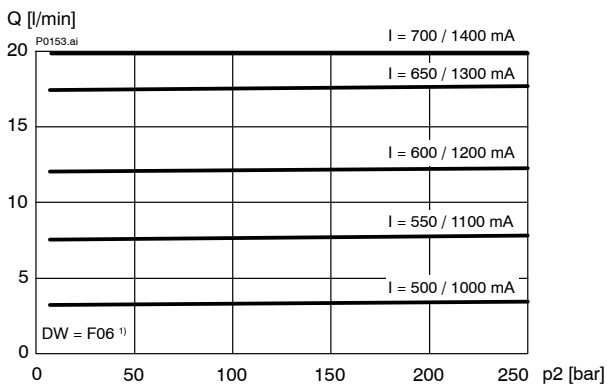

IMPORTANT!

1) Performance graphs measured with compensator model DWDPA-5D-10-F06-2

With optimised characteristic - $Q = f(I)$, type "S600" – with compensator (max. $\Delta p = 15$ bar)

$\Delta p = f(Q)$ Pressure drop - Flow rate characteristic

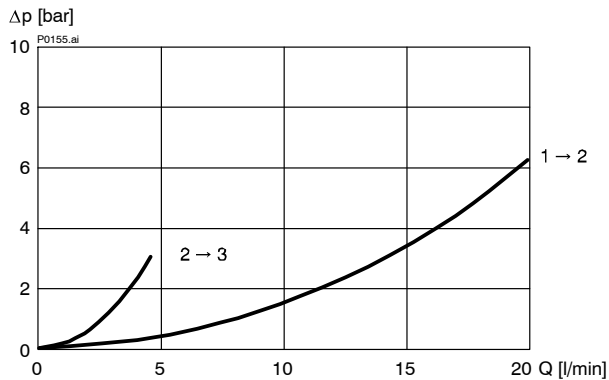

$Q = f(I; \Delta p)$ Flow rate adjustment characteristic

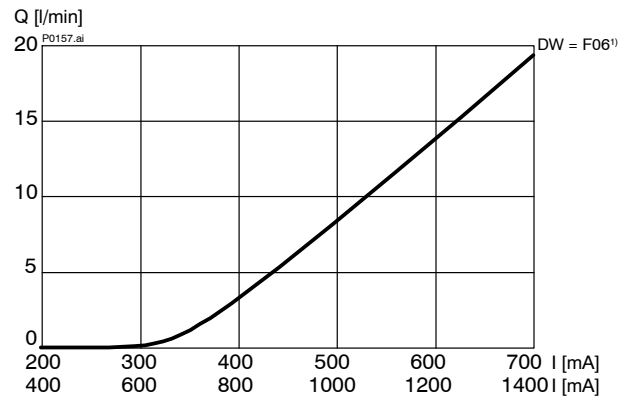

$Q = f(\Delta p; I)$ Flow rate adjustment characteristic

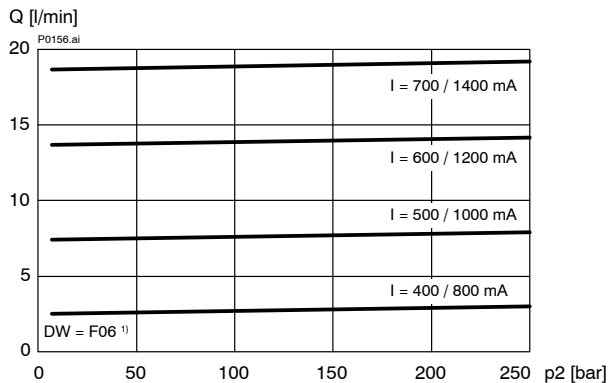

IMPORTANT!

1) Performance graphs measured with compensator model DWDP A-5D-10-F06-2

5 Installation information



IMPORTANT!

To achieve the proportional 3/2 throttle cartridge's maximum performance rating, fit the solenoid coil as shown (with the plug pins at the bottom). When fitting the cartridges, note the mounting attitude (preferably vertical, with coil down → automatic air bleed) and use the specified tightening torque. No adjustments are necessary, since the cartridges are set in the factory.



ATTENTION!

Only qualified personnel with mechanical skills may carry out any maintenance work. Generally, the only work that should ever be undertaken is to check, and possibly replace, the seals. When changing seals, oil or grease the new seals thoroughly before fitting them.

6 Dimensions & sectional view

Without manual flow setting – standard

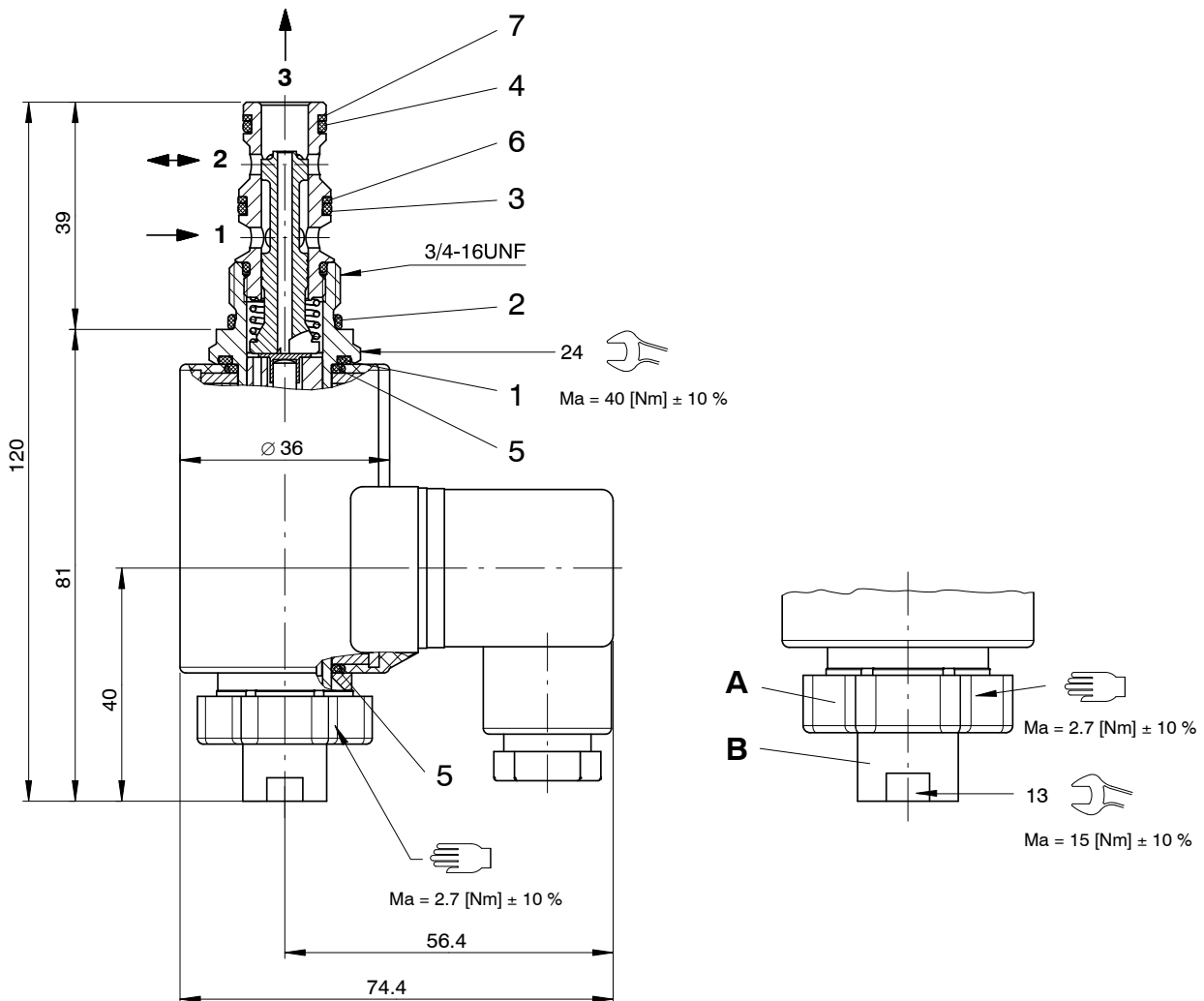

Seal kit NBR no. DS-247-N ²⁾

Item	Qty.	Description
1	1	O-ring $\varnothing 18,00 \times 2,00$ FKM
2	1	O-ring no. 017 $\varnothing 17,17 \times 1,78$ N90
3	1	O-ring no. 014 $\varnothing 12,42 \times 1,78$ N90
4	1	O-ring no. 013 $\varnothing 10,82 \times 1,78$ N90
5	2	O-ring $\varnothing 16,00 \times 2,00$ FKM
6	2	Backup ring $\varnothing 10,70 \times 1,45 \times 1,40$ FI0751
7	2	Backup ring $\varnothing 09,40 \times 1,45 \times 1,00$ FI0751



IMPORTANT!

²⁾ Seal kit with FKM (Viton) seals no. DS-247-V

Air-bleeding

If necessary, air can be purged from these proportional throttle cartridges by using the cap nut (Item B). The procedure is as follows:

- A Knurled nut
- B Cap nut

Steps:

1. Slacken and remove the knurled nut.
2. Slacken the cap nut approx. 1.5 turns.

Caution:

Slackening the cap nut allows oil to spray out!

3. Switch the proportional throttle cartridge ON/OFF several times until no more air bubbles escape.
4. Tighten the cap nut.
5. Refit the knurled nut and tighten it.

With manual flow setting – Option “E”

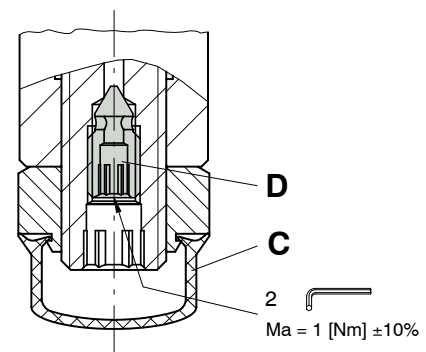
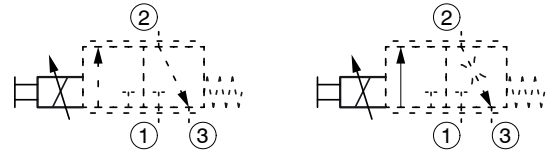
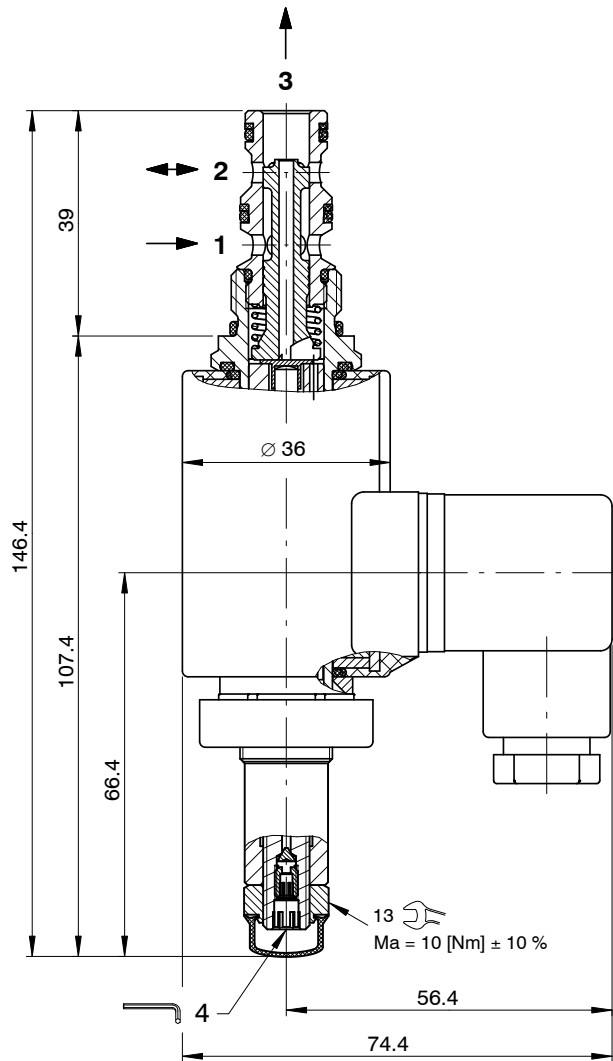

Integral air-bleeding

If necessary, air can be purged from these proportional throttle cartridges by using the integral air-bleed screw (Item D). The procedure is as follows:

- C Protective cap
- D Air-bleed screw

Steps:

1. Remove the protective cap.
2. Slacken the air-bleed screw approx. 2 turns.
3. Switch the proportional throttle cartridge ON/OFF several times until no more air bubbles escape.
4. Tighten the air-bleed screw.
5. Fit the protective cap.

7 Manual flow setting

Optionally, the proportional throttle cartridges can be supplied with an integral manual flow setting. If a proportional solenoid is faulty, for example, this manual flow setting enables the required flow rate to be set mechanically. This manual flow setting is not designed for adjusting the flow in a dynamic control mode.

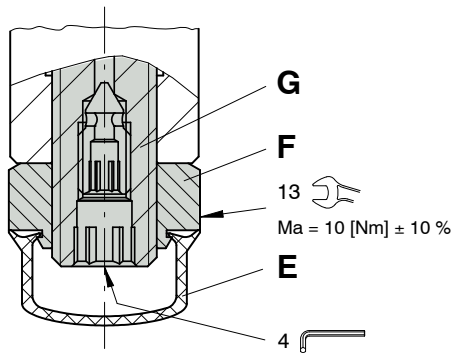

- E Protective cap
- F Lock nut (13 A/F)
- G Adjusting spindle for volume setting

Setting the flow rate manually

Steps:

1. Remove the protective cap.
2. Slacken the lock nut (13 A/F).
3. Screw in (turn to right) the adjusting spindle (4 A/F) until the required flow rate is set.
4. Tighten the lock nut (13 A/F).
5. Fit the protective cap.

Restoring the factory settings

Steps:

1. Solenoid de-energised.
2. Remove the protective cap.
3. Slacken the lock nut (13 A/F).
4. Unscrew the adjusting spindle (4 A/F) to its end-stop, then screw it in 2 turns.
5. Tighten the lock nut (13 A/F).
6. Fit the protective cap.

8 Application examples

Standard type "A"

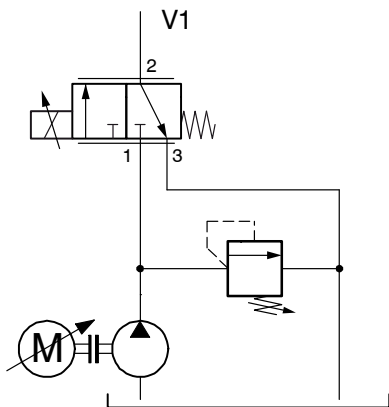

- Can be used without compensator (full Δp permissible)
- Full-flow connection 2 → 3
- Control is only available with connection 1 → 2

Special type “Z” – only to be used with compensator

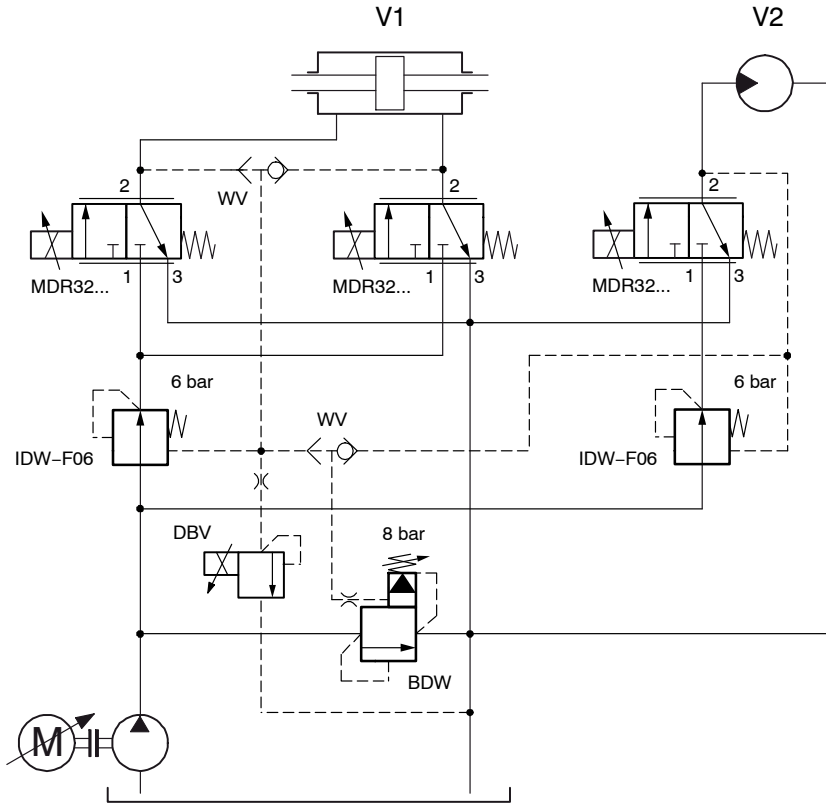

- Only for use with compensator (max. $\Delta p = 15$ bar)
- Full-flow connection 2 → 3
- Control is only available with connection 1 → 2

Special type “S600” – only to be used with compensator

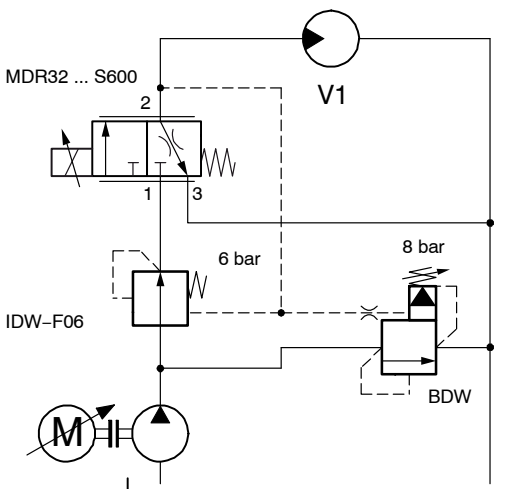

- Only for use with compensator (max. $\Delta p = 15$ bar)
- Connection 2 → 3 is not full flow (suitable for unloading)
- Control is only available with connection 1 → 2

9 Ordering code

Ex.

M	D	R	32G	N	A	5	_	-	_	-	1	24	D	_	_
---	---	---	-----	---	---	---	---	---	---	---	---	----	---	---	---

- M = flow-control valve
- D = direct acting
- R = proportional-solenoid operated
- 32G = 3/2 function, de-energised closed
- N = electrically operated, V DC = 27 W
- A ... Q = can be used with or without compensator (standard)
- Z = type only for use with compensator
- Y ... R = special features - please consult BUCHER
- 5 = nominal size 5
- (blank) = NBR (Nitrile) seals (standard)
- V = FKM (Viton) seals
(special seals - please contact BUCHER)
- (blank) = no manual flow setting (standard)
- E = with manual flow setting
- 1 ... 9 = design stage (omit when ordering new units)
- ... = voltage e.g. 24 (24 V)
- D = current DC
- (blank) = ISO 4400 / DIN 43 650 mating plug (standard, IP 65)
- M100 = without mating DIN plug

C	JT	IT	D	DT	S	F
= Kostal plug connection (IP 65)	= Junior Timer radial plug connection (with protection diode, IP65)	= Junior Timer axial plug connection (with protection diode, IP65)	= Deutsch plug connection DT04-2P (IP 67/69K)	= Deutsch plug connection DT04-2P (with protection diode, IP 67/69K)	= AMP Superseal 1.5 (IP 67) / Metri-Pack 150 (IP 65)	= flying leads (500 mm)

} mating plug not supplied

- Ohne = types ("A" or "Z")
- S600 = type with optimised characteristic - $Q = f(I)$, only for use with compensator

10 Related data sheets

Reference	(Old no.)	Description
400-P-040011	(i-32)	The form-tool hire programme
400-P-040181	(i-33.11)	Cavity type AM
400-P-120110	(W-2.141)	Coils for screw-in cartridge valves
400-P-510101		Amplifier unit for proportional valves (1-channel) PBS - 3A
400-P-511101		Amplifier card for proportional valves (1-channel) SAN-535...
400-P-720111	(G-4.20)	Line-mounting body, type GAMA (G 3/8")

info.ch@bucherhydraulics.com

www.bucherhydraulics.com

© 2015 by Bucher Hydraulics AG Frutigen, CH-3714 Frutigen

All rights reserved.

Data is provided for the purpose of product description only, and must not be construed as warranted characteristics in the legal sense. The information does not relieve users from the duty of conducting their own evaluations and tests. Because the products are subject to continual improvement, we reserve the right to amend the product specifications contained in this catalogue.

Classification: 430.310.325.305.310.310

Proportional 4/2 Throttle Cartridge, Size 5

$Q_{\max} = 30 \text{ l/min}$, $p_{\max} = 250 \text{ bar}$
Sliding-spool design, direct acting
Series MDR42...-5...

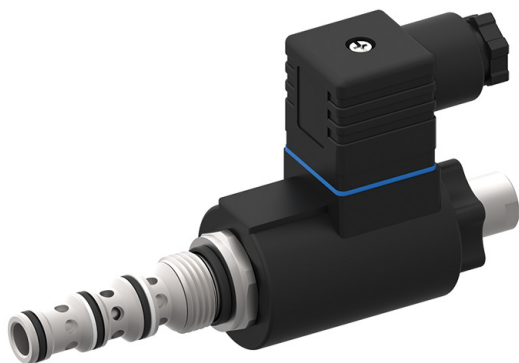

- Compact construction for cavity type AN – 3/4-16 UNF
- Dual flow paths for higher flow rate
- Low headloss
- For use with inline or bypass pressure-compensator cartridges
- Reliable operation over the whole pressure and flow range
- With optional manual flow setting
- All exposed parts with zinc-nickel plating
- High pressure wet-armature solenoids
- The slip-on coil can be rotated, and it can be replaced without opening the hydraulic envelope
- Various plug-connector systems and voltages are available

1 Description

Series MDR42... direct acting proportional 4/2 throttle valves are size 5, high performance screw-in cartridges with a 3/4-16 UNF mounting thread. They are designed on the proven sliding-spool principle. The straightforward design delivers an outstanding price/performance ratio. "De-energised closed" and "de-energised open" functions are available. In control mode, the flow through the connections 1 → 3 and 4 → 2 is varied in proportion to the control current. Thanks to these dual flow paths, a higher flow rate is achieved with low headloss. It is essential that ports 1 + 4, and likewise 2 + 3, are joined together in the valve housing (manifold block).

In combination with inline or bypass compensators, these 4/2 throttle cartridges are predominantly used in mobile and industrial applications to allow a flow in hydraulic installations to be controlled electro-proportionally. All external parts of the cartridge are zinc-nickel plated to DIN 50 979 and are thus suitable for use in the harshest operating environments. The slip-on coils can be replaced without opening the hydraulic envelope and can be positioned at any angle through 360°. If you intend to manufacture your own cavities or are designing a line-mounting installation, please refer to the section "Related data sheets".

2 Symbol

Dual flow paths

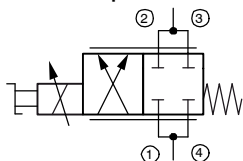

MDR42AD...-E

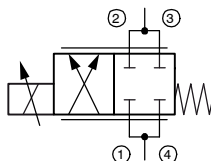

MDR42AD...

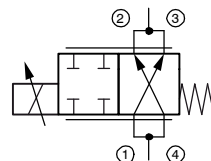

MDR42ANK...



IMPORTANT!

To enable the dual flow-path function, ports 1 + 4 and 2 + 3 must be connected within the valve housing (manifold block).

3 Technical data

General characteristics	Description, value, unit
Designation	proportional 4/2 throttle cartridge
Design	sliding-spool design, direct acting
Mounting method	screw-in cartridge 3/4-16 UNF
Tightening torque	40 Nm ± 10 %
Size	nominal size 5, cavity type AN
Weight	0.40 kg
Mounting attitude	unrestricted (preferably vertical, coil down)
Ambient temperature range	-25 °C ... +50 °C

Hydraulic characteristics	Description, value, unit
Maximum operating pressure	250 bar
Maximum flow rate	30 l/min
Nominal flow rate 1 + 4 → 2 + 3	25 l/min at $\Delta p = 4$ bar
Leakage flow rate	< 150 cm ³ /min (with p_N 250 bar) with oil viscosity 33 mm ² /s (cSt)
Flow direction	see symbols
Hydraulic fluid	HL and HLP mineral oil to DIN 51 524; for other fluids, please contact BUCHER
Hydraulic fluid temperature range	-25 °C ... +70 °C
Viscosity range	15...380 mm ² /s (cSt), recommended 20...130 mm ² /s (cSt)
Minimum fluid cleanliness Cleanliness class to ISO 4406 : 1999	class 18/16/13

Electrical characteristics	Description, value, unit
Supply voltage	12 V DC, 24 V DC
Control current	12 V = 0...1400 mA, 24 V = 0...760 mA
Power consumption at max. control current	max. 19 W
Coil resistance R - cold value at 20 °C - max. warm value	12 V = 5.8 Ω / 24 V = 21 Ω 12 V = 8.6 Ω / 24 V = 32 Ω
Recommended PWM frequency (dither)	200 Hz
Hysteresis with PWM	2...4 % I_N
Reversal error with PWM	2...4 % I_N
Sensitivity with PWM	< 1 % I_N
Reproducibility with PWM	< 2 % p_N
Relative duty cycle	100 %
Protection class to ISO 20 653 / EN 60 529	IP 65 / IP 67 / IP 69K, see "Ordering code" (with appropriate mating connector and proper fitting and sealing)
Electrical connection	3-pin square plug to ISO 4400 / DIN 43 650 (standard) for other connectors, see "Ordering code"

4 Performance graphs measured with oil viscosity 33 mm²/s (cSt)

For use with compensator (max. $\Delta p = 15$ bar)

$\Delta p = f(Q)$ Pressure drop - Flow rate characteristic

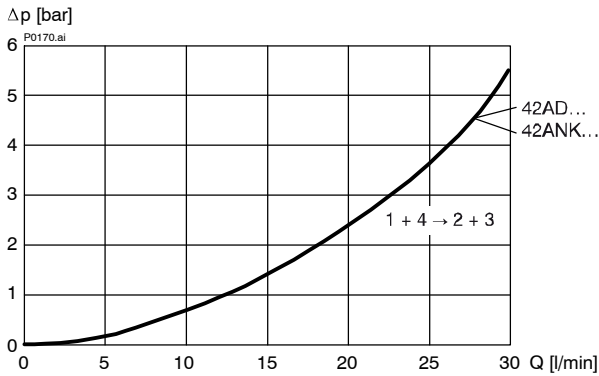

$Q = f(I; \Delta p)$ Flow rate adjustment characteristic

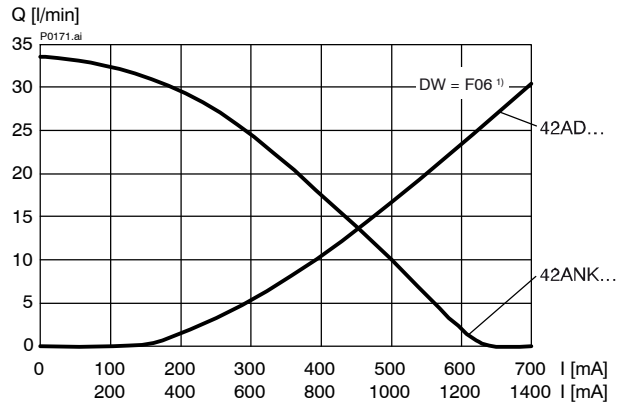

$Q = f(\Delta p; I)$ Flow rate adjustment characteristic MDR42AD...

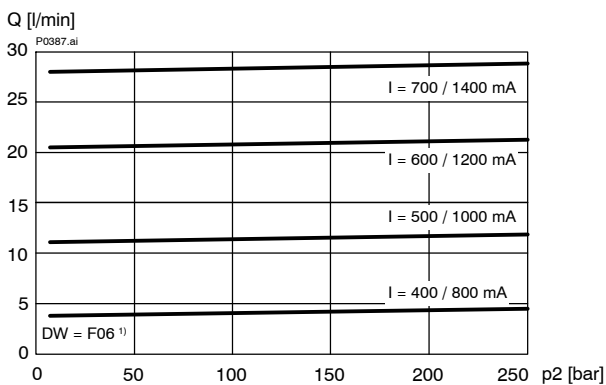

$Q = f(\Delta p; I)$ Flow rate adjustment characteristic MDR42ANK...

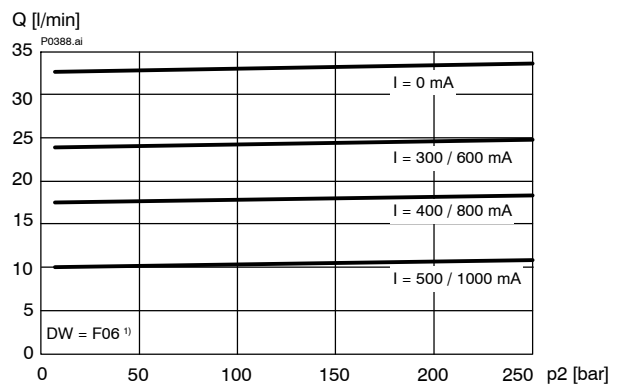

IMPORTANT!

1) Performance graphs measured with compensator model DWDPA-5D-10-F06-2

5 Installation information



IMPORTANT!

To achieve the proportional 4/2 throttle cartridge's maximum performance rating, fit the solenoid coil as shown (with the plug pins at the bottom). When fitting the cartridges, note the mounting attitude (preferably vertical, with coil down → automatic air bleed) and use the specified tightening torque. No adjustments are necessary, since the cartridges are set in the factory.



ATTENTION!

Only qualified personnel with mechanical skills may carry out any maintenance work. Generally, the only work that should ever be undertaken is to check, and possibly replace, the seals. When changing seals, oil or grease the new seals thoroughly before fitting them.

6 Dimensions & sectional view

Without manual flow setting – standard

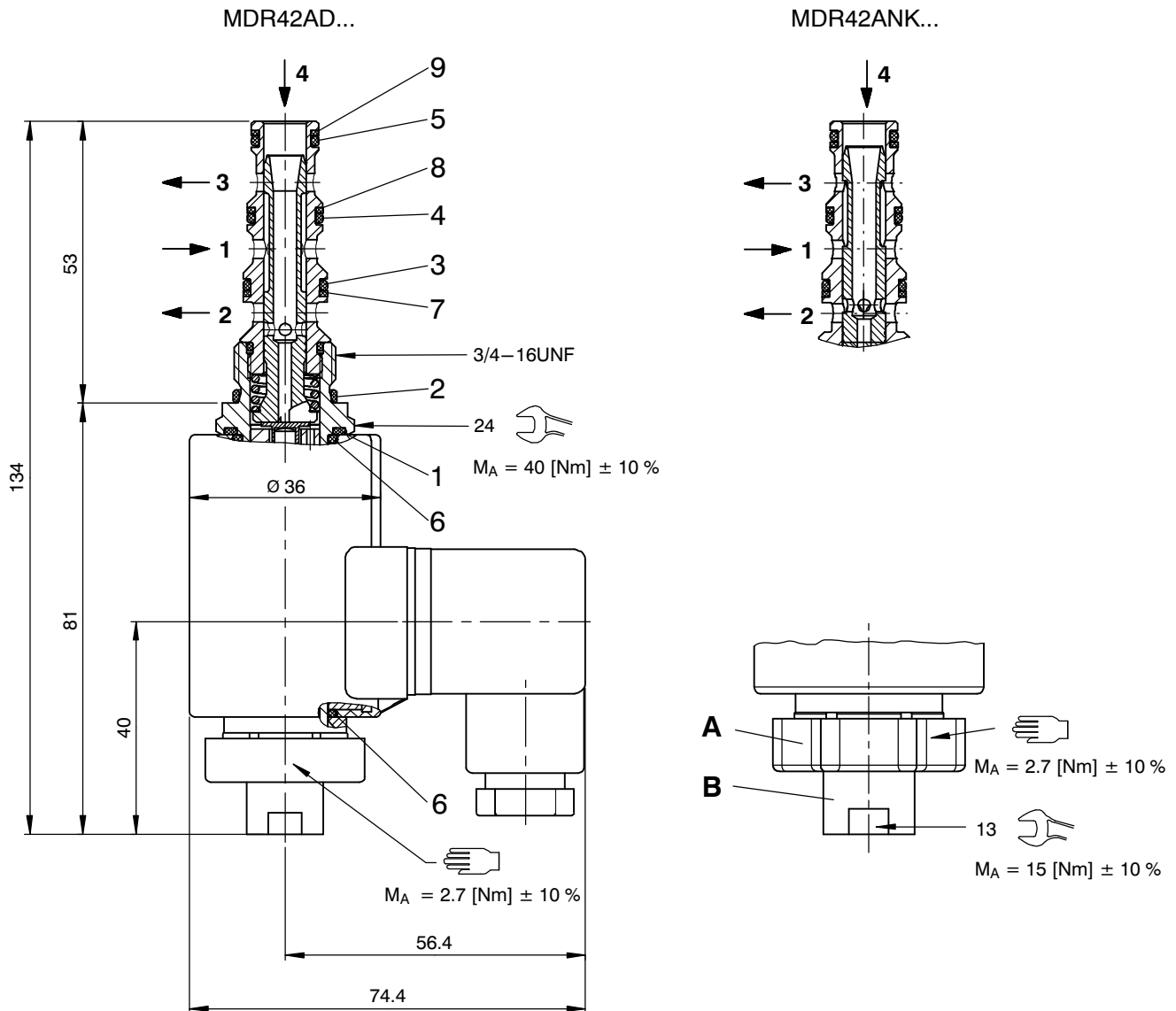

Seal kit no. DS-248-N ²⁾

Item	Qty.	Description
1	1	O-ring $\varnothing 18,00 \times 2,00$ FKM
2	1	O-ring no. 017 $\varnothing 17,17 \times 1,78$ N90
3	1	O-ring no. 014 $\varnothing 12,42 \times 1,78$ N90
4	1	O-ring no. 013 $\varnothing 10,82 \times 1,78$ N90
5	1	O-ring no. 012 $\varnothing 09,25 \times 1,78$ N90
6	2	O-ring $\varnothing 16,00 \times 2,00$ FkM
7	1	Backup ring $\varnothing 10,70 \times 1,45 \times 1,40$ FI0751
8	1	Backup ring $\varnothing 09,40 \times 1,45 \times 1,00$ FI0751
9	1	Backup ring $\varnothing 07,80 \times 1,45 \times 1,00$ FI0751



IMPORTANT!

²⁾ Seal kit with FKM (Viton) seals no. DS-248-V

Air-bleeding

If necessary, air can be purged from these proportional throttle cartridges by using the cap nut (Item B). The procedure is as follows:

- A Knurled nut
- B Cap nut

Steps:

1. Slacken and remove the knurled nut.
2. Slacken the cap nut approx. 1.5 turns.
Caution: Slackening the cap nut allows oil to spray out!
3. Switch the proportional throttle cartridge ON/OFF several times until no more air bubbles escape.
4. Tighten the cap nut.
5. Refit the knurled nut and tighten it.

With manual flow setting – Option “E”

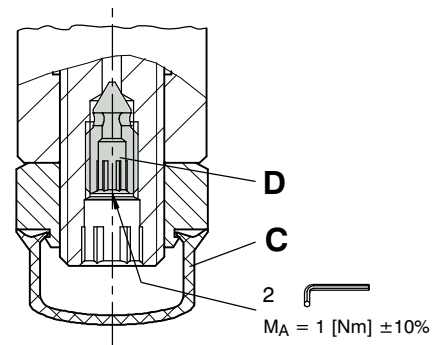
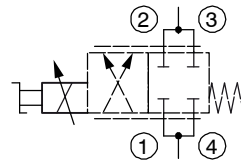
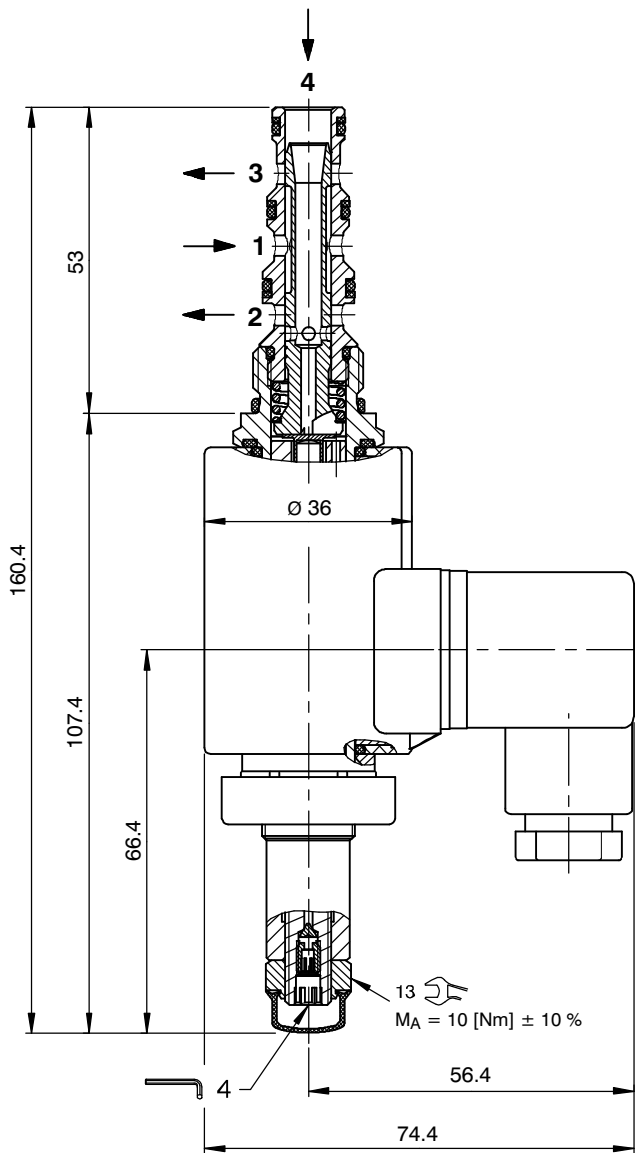

Integral air-bleeding

If necessary, air can be purged from these proportional throttle cartridges by using the integral air-bleed screw (Item D). The procedure is as follows:

- C Protective cap
- D Air-bleed screw

Steps:

1. Remove the protective cap.
2. Slacken the air-bleed screw approx. 2 turns.
3. Switch the proportional throttle cartridge ON/OFF several times until no more air bubbles escape.
4. Tighten the air-bleed screw.
5. Fit the protective cap.

7 Manual flow setting

Optionally, the proportional throttle cartridges can be supplied with an integral manual flow setting. If a proportional solenoid is faulty, for example, this manual flow setting enables the required flow rate to be set mechanically. This manual flow setting is not designed for adjusting the flow in a dynamic control mode.

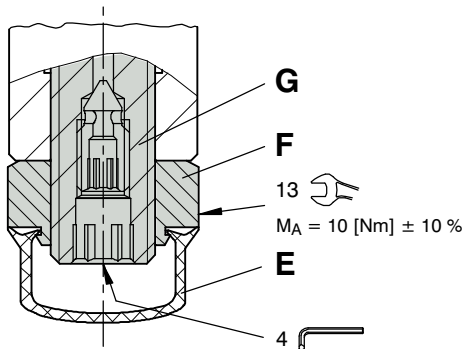

- E Protective cap
- F Lock nut (13 A/F)
- G Adjusting spindle for volume setting

Setting the flow rate manually

Steps:

1. Remove the protective cap.
2. Slacken the lock nut (13 A/F).
3. Screw in (turn to right) the adjusting spindle (4 A/F) until the required flow rate is set.
4. Tighten the lock nut (13 A/F).
5. Fit the protective cap.

Restoring the factory settings

Steps:

1. Solenoid de-energised.
2. Remove the protective cap.
3. Slacken the lock nut (13 A/F).
4. Unscrew the adjusting spindle (4 A/F) to its end-stop, then screw it in 2 1/8 turns.
5. Tighten the lock nut (13 A/F).
6. Fit the protective cap.

8 Application examples

Used with bypass pressure-compensator cartridge

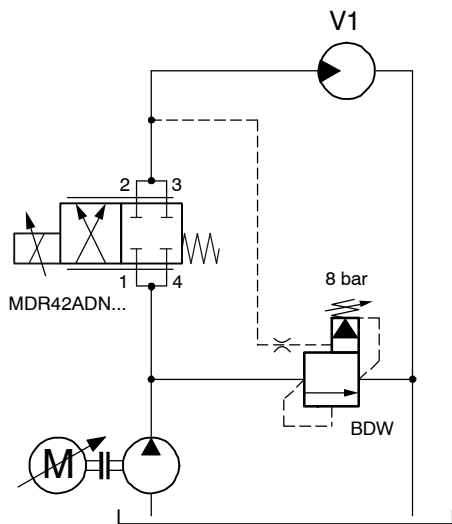

Classic combination with inline and bypass pressure-compensator cartridges

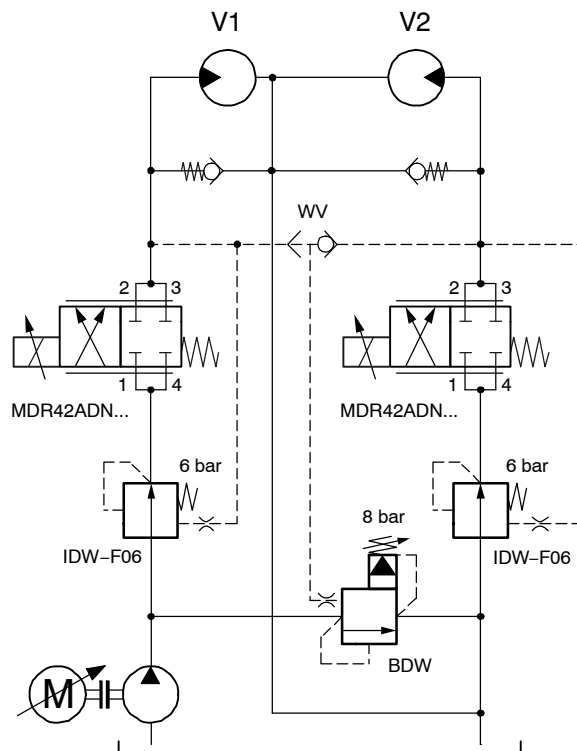

9 Ordering code

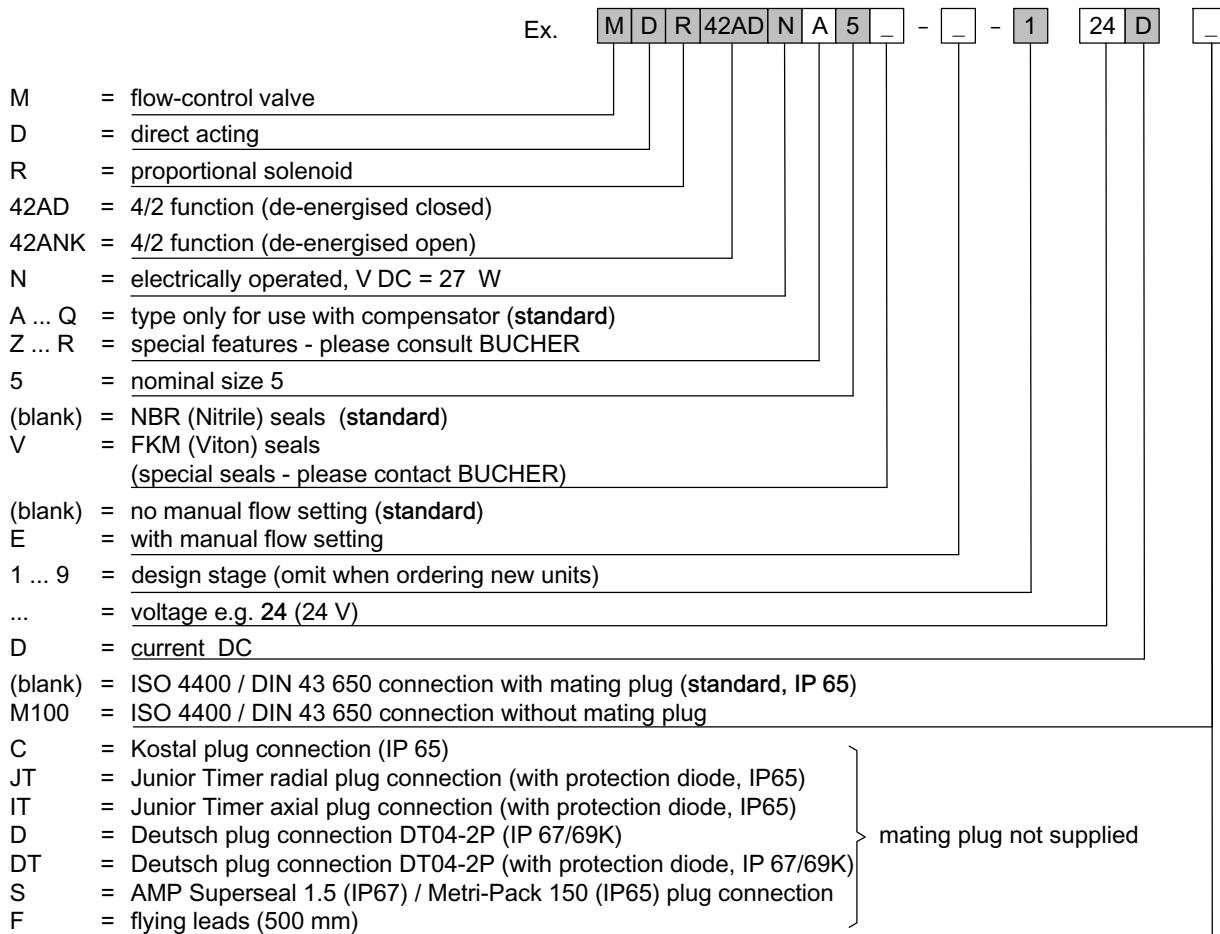

10 Related data sheets

Reference	(Old no.)	Description
400-P-040011	(i-32)	The form-tool hire programme
400-P-040181	(i-33.12)	Cavity type AN
400-P-120110	(W-2.141)	Coils for screw-in cartridge valves series D36
400-P-510101		Amplifier unit for proportional valves (1-channel) PBS - 3A
400-P-511101		Amplifier card for proportional valves (1-channel) SAN-535...

info.ch@bucherhydraulics.com

www.bucherhydraulics.com

© 2016 by Bucher Hydraulics AG Frutigen, CH-3714 Frutigen

All rights reserved.

Data is provided for the purpose of product description only, and must not be construed as warranted characteristics in the legal sense. The information does not relieve users from the duty of conducting their own evaluations and tests. Because the products are subject to continual improvement, we reserve the right to amend the product specifications contained in this catalogue.

Classification: 430.310.325.305.310.310

Proportional Throttle Cartridges, Size 5 / SAE 08

$Q_{\max} = 50 \text{ l/min (13 gpm)}$, $p_{\max} = 250 \text{ bar (3600 psi)}$

Two-Stage, with Seat-Valve Shut-Off

Series MVRPSBA-...



- De-energised closed
- Seat-valve shut-off in flow direction (see symbol)
- $Q_N = 20 \text{ l/min (5.3 gpm)}$ at $\Delta p 10 \text{ bar (140 psi)}$
- Compact construction for cavity types:
AL or C0820 – 3/4-16 UNF
- Reliable operation over the whole pressure and flow range (even at high pressure differences)
- Low headloss
- All exposed parts with zinc-nickel plating
- High pressure wet-armature solenoids
- The slip-on coil can be rotated, and it can be replaced without opening the hydraulic envelope
- Various plug-connector systems and voltages are available
- Can be fitted in a line-mounting body

1 Description

Series MVRPSBA-... two-stage proportional throttle cartridges are size 5 / SAE 08, high performance screw-in valves with a 3/4-16 UNF mounting thread. The main and pilot stages are designed on the poppet/seat principle and are therefore virtually leak-free in the flow direction (see symbol). With these proportional throttle cartridges, the flow rate is dependent on the electrical control current, and it can be varied continuously and responsively. When used with a pressure compensator, these cartridges are particularly suitable for precise and load-compensated lifting and

lowering movements, but they can also be used on their own for reliable operation in mobile and industrial applications with large pressure differences. All external parts of the cartridge are zinc-nickel plated to DIN 50 979 and are thus suitable for use in the harshest operating environments. The slip-on coils can be replaced without opening the hydraulic envelope and can be positioned at any angle through 360°. If you intend to manufacture your own cavities or are designing a line-mounting installation, please refer to the section "Related data sheets".

2 Symbol

Cavity type AL

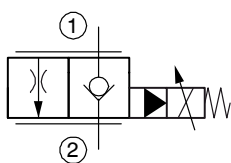

MVRPSBA-LG... (size 5)

Cavity type C0820

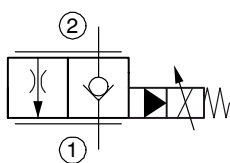

MVRPSBA-2G... (SAE08)

3 Technical data

General characteristics	Description, value, unit
Designation	proportional-throttle cartridge
Design	seat-valve shut-off, two stage
Mounting method	screw-in cartridge 3/4-16 UNF
Tightening torque	40 Nm \pm 10 % (30 ft-lbs \pm 10 %)

General characteristics	Description, value, unit
Size	nominal size 5 for cavity type AL size SAE 08 for cavity type C0820
Weight	0.40 kg (0.9 lbs)
Mounting attitude	unrestricted (preferably vertical, coil down)
Ambient temperature range	-25 °C ... +50 °C (-13 °F ... +122 °F)

Hydraulic characteristics	Description, value, unit
Maximum operating pressure	250 bar (3600 psi)
Maximum flow rate	50 l/min (13 gpm)
Nominal flow rate	20 l/min at $\Delta p = 10$ bar (5.3 gpm at $\Delta p = 140$ psi)
Leakage flow rate	< 0,2 cm ³ /min (max. 5 drops/min) with oil viscosity 33 mm ² /s (cSt)
Flow direction	see symbol
Hydraulic fluid	HL and HLP mineral oil to DIN 51 524; for other fluids, please contact BUCHER
Hydraulic fluid temperature range	-25 °C ... +70 °C (-13 °F ... +158 °F)
Viscosity range	15...380 mm ² /s (cSt), recommended 20...130 mm ² /s (cSt)
Minimum fluid cleanliness Cleanliness class to ISO 4406 : 1999	class 18/16/13

Electrical characteristics	Description, value, unit
Supply voltage	12 V DC, 24 V DC
Control current	12 V = 0...1400 mA, 24 V = 0...760 mA
Coil resistance R - cold value at 20 °C - max. warm value	12 V = 5.8 Ω / 24 V = 20.9 Ω 12 V = 9.1 Ω / 24 V = 32.7 Ω
Recommended PWM frequency (dither)	200 Hz
Hysteresis with PWM	3...6 % I _N
Reversal error with PWM	3...6 % I _N
Sensitivity with PWM	< 2 % I _N
Reproducibility with PWM	< 3 % p _N
Switching time	see performance graphs
Relative duty cycle	100 %
Protection class to ISO 20 653 / EN 60 529	IP 65 / IP 67 / IP 69K, see "Ordering code" (with appropriate mating connector and proper fitting and sealing)
Electrical connection	3-pin square plug to ISO 4400 / DIN 43 650 (standard) for other connectors, see "Ordering code"

4 Performance graphs

measured with oil viscosity 33 mm²/s (cSt) – for cavity type AL and C0820

$\Delta p = f(Q)$ Pressure drop - Flow rate characteristic
"energized"

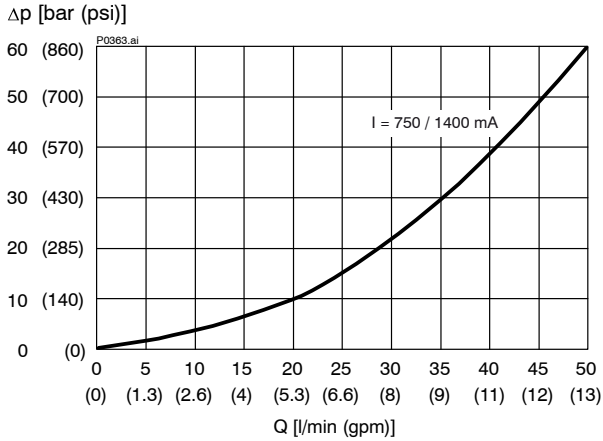

$\Delta p = f(Q)$ Pressure drop - Flow rate characteristic
"de-energized - through check valve"

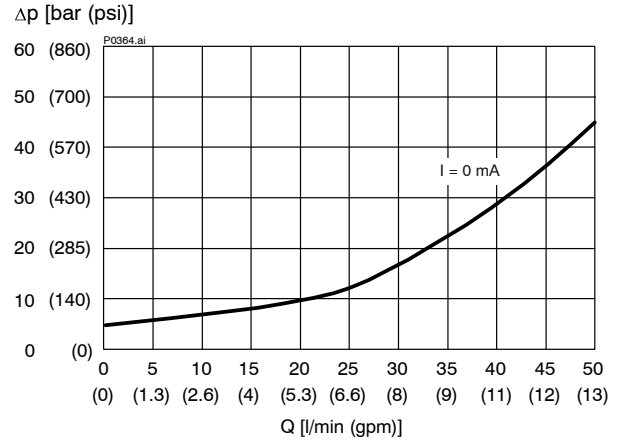

Attention:

When flow passes through the check valve and there is a large pressure difference, the poppet in the main stage can be damaged.

$Q = f(\Delta p; I)$ Flow rate adjustment characteristic

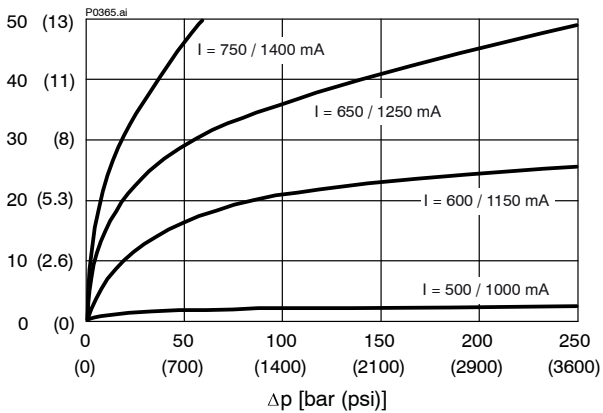

$Q = f(I; \Delta p)$ Flow rate adjustment characteristic

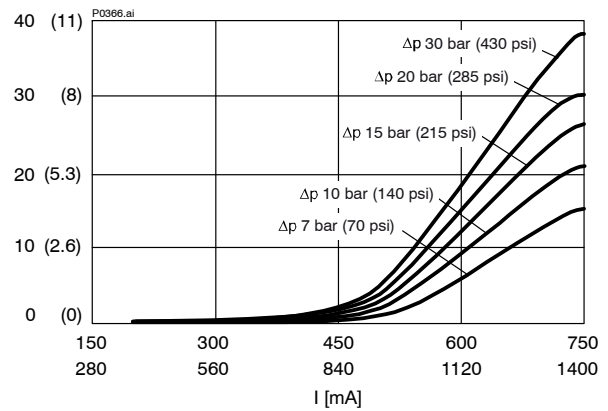

Switching time measured up to 80 % change in the pressure difference. Electrical operation with DC power supply.

$t = f(I; \Delta p)$ Switching time characteristic Opening
at $\Delta p = 10 \dots 50$ bar (140 ... 700 psi)

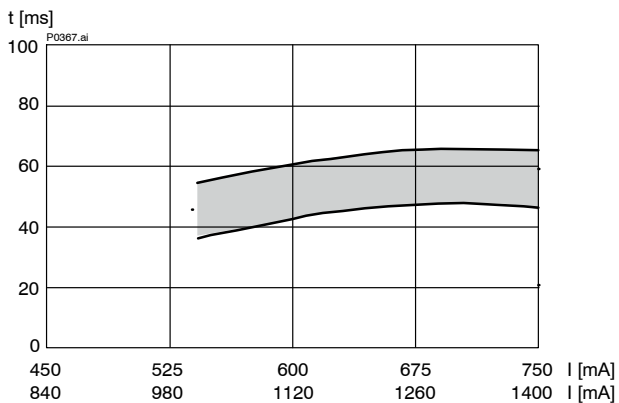

$t = f(I; \Delta p)$ Switching time characteristic Closing
at $\Delta p = 10 \dots 50$ bar (140 ... 700 psi)

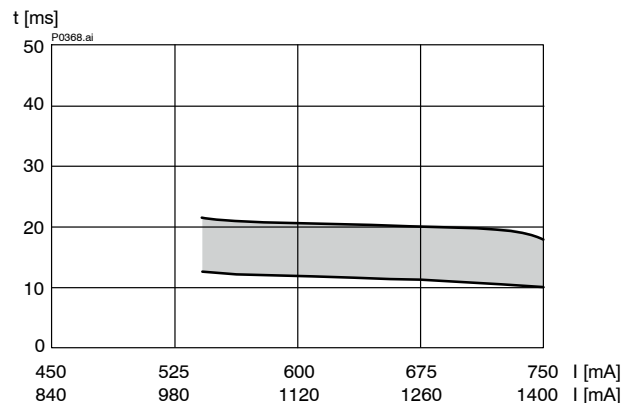

5 Dimensions & sectional view

Dimensions in millimeters (inches)

5.1 Insertion in cavity type "AL"

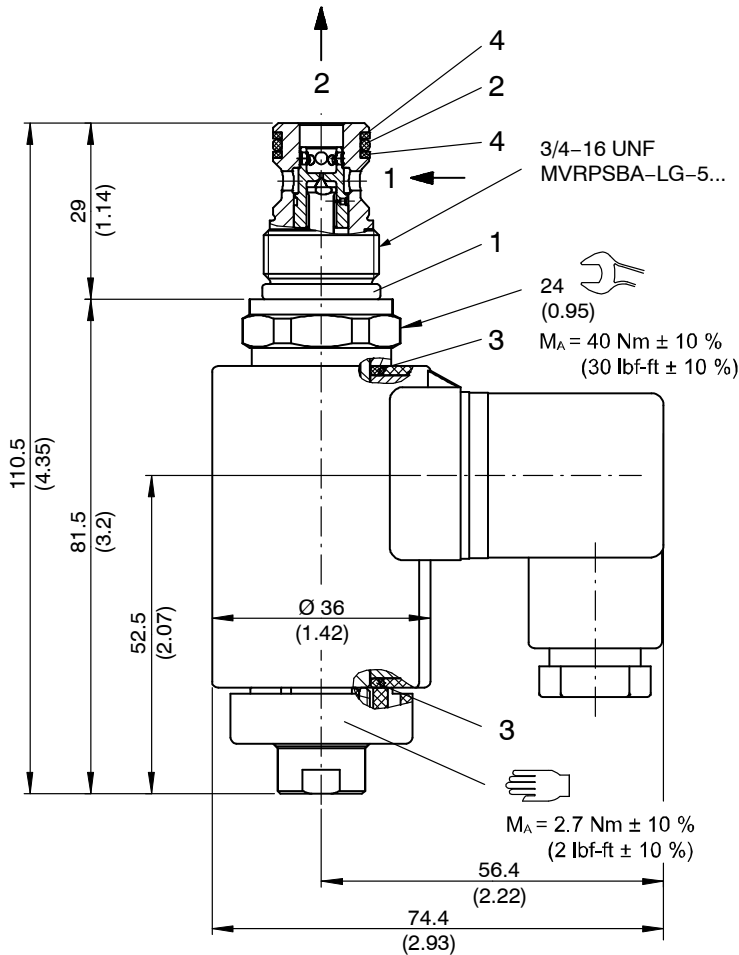

5.2 Insertion in cavity type "C0820"

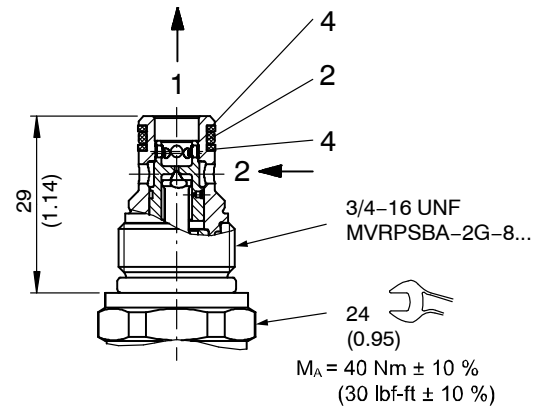

6 Installation information



Important:

When fitting the cartridges, note the mounting attitude (preferably vertical, with coil down → automatic air bleed) and use the specified tightening torque. No adjustments are necessary, since the cartridges are set in the factory.



ATTENTION!

Only qualified personnel with mechanical skills may carry out any maintenance work. Generally, the only work that should ever be undertaken is to check, and possibly replace, the seals. When changing seals, oil or grease the new seals thoroughly before fitting them.

Seal kit NBR no. DS-447-N (cavity type AL) ¹⁾

Item	Qty.	Description
1	1	O-ring no. 017 Ø 17.17 x 1.78 N90
2	1	O-ring no. 014 Ø 12.42 x 1.78 N90
3	2	O-ring Ø 16.00 x 2.00 FKM
4	2	Backup ring Ø 10.70 x 1.45 x 1.00 FI0751



IMPORTANT!

1) Seal kit with FKM (Viton) seals, no. DS-447-V

Seal kit NBR no. DS-448-N (cavity type C0820) ²⁾

Item	Qty.	Description
1	1	O-ring no. 017 Ø 17.17 x 1.78 N90
2	1	O-ring no. 012 Ø 9.25 x 1.78 N90
3	2	O-ring Ø 16.00 x 2.00 FKM
4	2	Backup ring Ø 7.80 x 1.45 x 1.00 FI0751



IMPORTANT!

2) Seal kit with FKM (Viton) seals, no. DS-448-V

7 Application examples

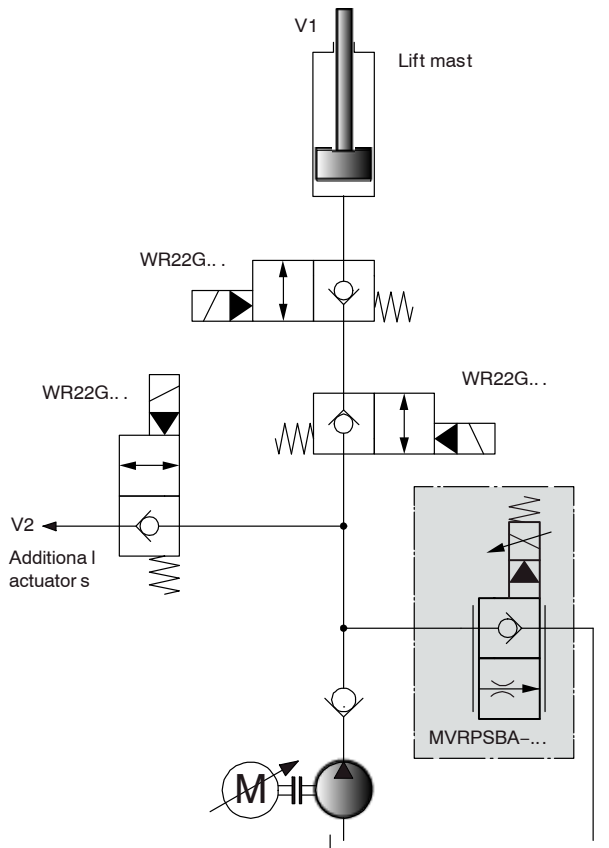

Potential applications

- Lifting and lowering movements on industrial trucks
- In agricultural machines, e.g. proportional scraper-floor controls in self-loading trailers
- In all applications where a load-independent function is required, in combination with our in-line or bypass pressure compensators

8 Ordering code

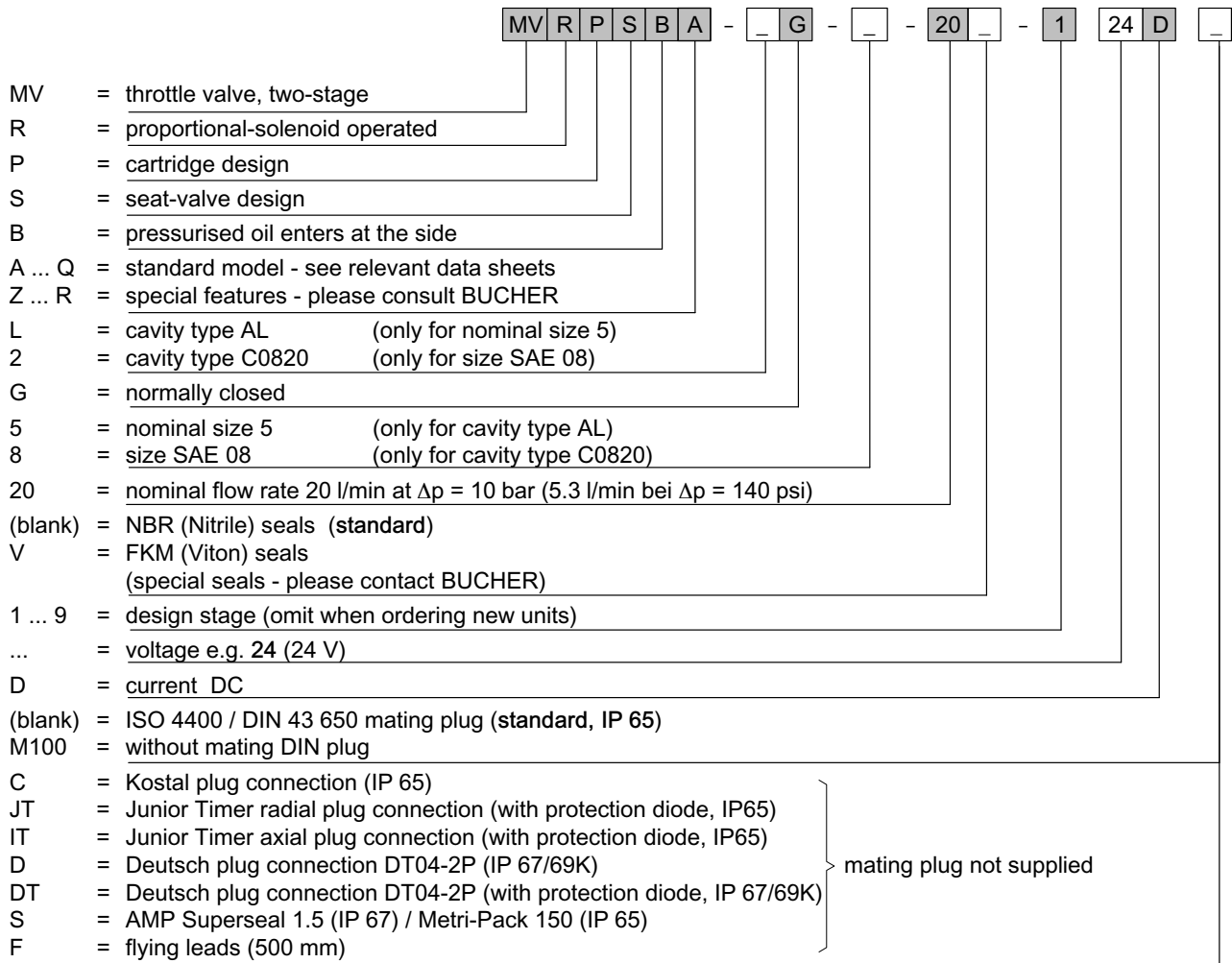

9 Related data sheets

Reference	(Old no.)	Description
400-P-040011	(i-32)	The form-tool hire programme
400-P-040171		Cavity type AL
520-P-000110		Cavity type C0820
400-P-120110	(W-2.141)	Coils for screw-in cartridge valves
400-P-510101		Amplifier unit for proportional valves (1-channel) PBS - 3A
400-P-511101		Amplifier card for proportional valves (1-channel) SAN-535...
400-P-720101		Line-mounting body, type GALA (G 3/8")
520-P-000111		Line-mounting body, size SAE 08 (G 3/8")

info.ch@bucherhydraulics.com

www.bucherhydraulics.com

© 2015 by Bucher Hydraulics AG Frutigen, CH-3714 Frutigen

All rights reserved.

Data is provided for the purpose of product description only, and must not be construed as warranted characteristics in the legal sense. The information does not relieve users from the duty of conducting their own evaluations and tests. Because the products are subject to continual improvement, we reserve the right to amend the product specifications contained in this catalogue.

Classification: 430.310.325.305.310.310

PRESSURE COMPENSATED, NORMALLY CLOSED OR NORMALLY OPEN PROPORTIONAL, IN-LINE FLOW CONTROL VALVE.

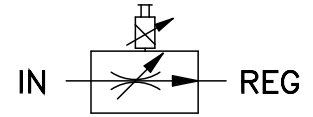

UL approved coil, IP68 and IP69K rated when used with waterproof connector.

LIMITED RANGE ADJUSTMENT (SCREW TYPE)

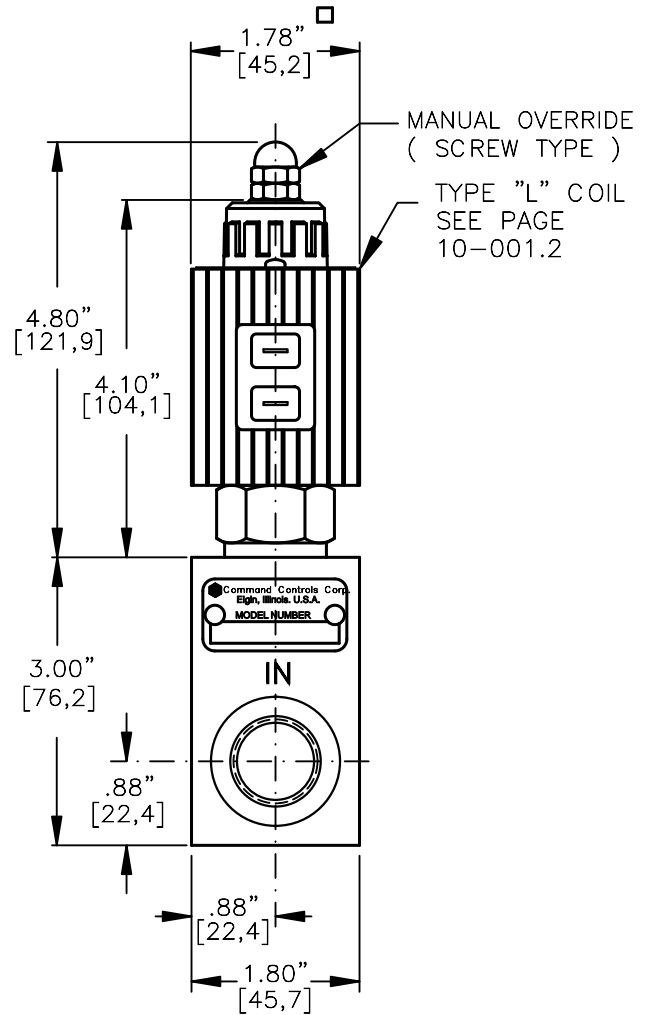
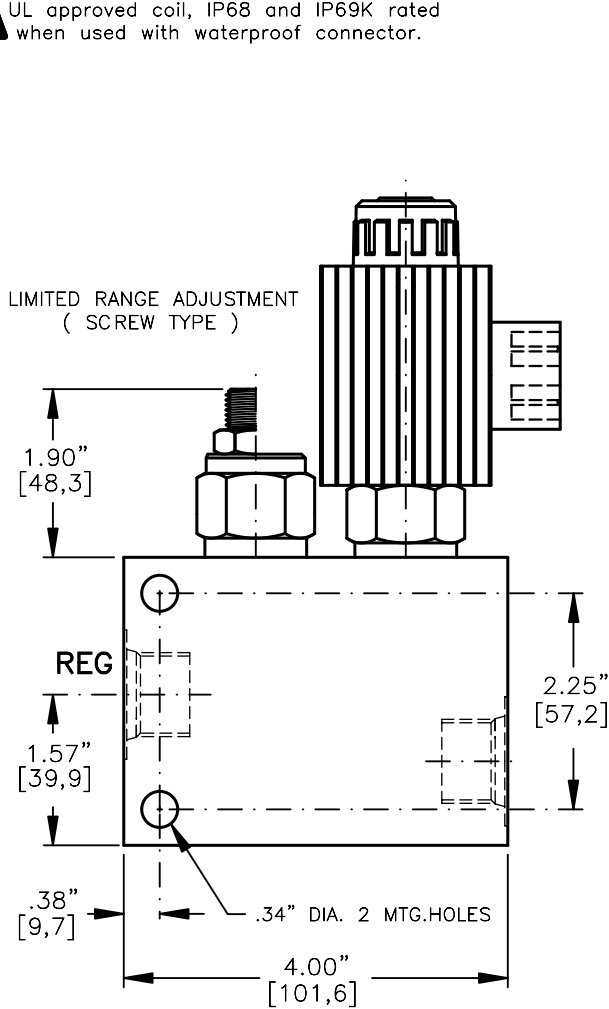

NOTES:
1. SOLENOIDS AVAILABLE WITH DIODES - CONSULT FACTORY.

PIFC-10-X-X-XX-X-X-X-XXX-XXX X

BASIC

SIZE
10= 7/8"-14UNF

SEALS
N = BUNA "N"
V = VITON

STYLE
C = NORMALLY CLOSED
O = NORMALLY OPEN

REGULATED FLOW
04 = 0 TO 4.0 GPM
08 = 0 TO 8.0 GPM
12 = 0 TO 12.0 GPM
16 = 0 TO 16.0 GPM

TERMINALS

L = 18GA. 24" LEADS
T = SPADE TERM.
B = BOLT TERM.
G = DIN43650
W = WEATHER-PACK
D = DEUTSCH-DT04-2P
M = METRI-PACK CONN.
VOLTAGE AMPS
12D = 12 VDC 3.00
24D = 24 VDC 1.50

ADJUSTMENT OPTIONS

O-F-100 = NONE
M-F-100 = MANUAL OVERRIDE
O-S-160 = LIMITED RANGE ADJ.
M-S-160 = BOTH MO/LTD ADJ.

PORTS

10TX = SAE - #10
"A" = ALUM. HOUSING
"S" = STEEL HOUSING

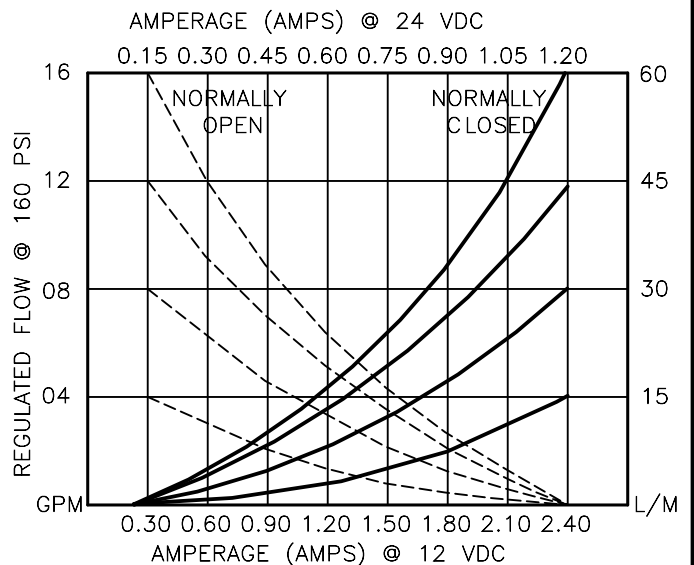

PRESSURE COMPENSATED, PROPORTIONAL, IN-LINE, FLOW CONTROL VALVE.**DESCRIPTION**

This valve is an electro-hydraulic, proportional, in-line (Restrictive) type, pressure compensated, hydraulic flow control. Regulated flow Normally Closed 0 to 16.0 GPM, [0 to 61,0 L/m] max. Normally Open 16.0 to 0 GPM [61,0 to 0 L/m] is proportional to the current input, regardless of load or system pressure.

OPERATIONS

This unit is a direct acting (NO PILOT FLOW), electro-hydraulic, proportional, pressure compensated, flow control valve. When the coil is energized the armature moves the metering orifice open or close against a precision bias spring varying the flow. A pressure compensator spool (HYDROSTAT) modulates the flow at 160 PSI/11,0 Bar delta "P" providing the valve with a constant regulated flow regardless of load or system pressure. When current is increased or decreased to the coil; the flow will increase or decrease proportionally.

IN THE EVENT OF POWER FAILURE THE VALVE WILL CLOSE OR OPEN RESPECTIVELY.

FEATURES AND BENEFITS

Continuous-duty, very low heat rise & waterproof solenoid coil.
Interchangeable solenoid coils & terminations options available.
Hardened precision fitted spool & sleeve provides reliable, long life.
Very efficient wet – armature solenoid core tube construction.
All external carbon steel parts are plated for longer life against the elements.
All valves are 100% functionally tested.

PRESSURE COMPENSATED, PROPORTIONAL, IN-LINE, FLOW CONTROL VALVE.

SPECIFICATIONS

OPERATING PRESSURE: 5,000 PSI [350 Bar]

PROOF PRESSURE: 10,000 PSI [700 Bar]

REGULATED FLOW: 16.0 GPM [61,0 L/m] Max. See performance chart.

INTERNAL LEAKAGE: 15 cu.in/min [245 cc/m] @ 5,000 PSI [350 Bar]

VALVE HOUSINGS: 2500 PSI [175 Bar] = Aluminum – Anodized.

5000 PSI [350 Bar] = Steel – Unplated.

OPERATING TEMPERATURE: -40° to +250° F. [-40° to +120° C.]

OPERATING MEDIA: All general purpose hydraulic fluids such as

MIL-H-5606, SAE-#10, SAE-#20, etc.

RESPONSE: The most efficient method to control this valve is with
current control and a 50 Hz dither.

POWER REQUIREMENTS: 12 VDC, Operating current 0.4 to 2.4 AMPS.

24 VDC, Operating current 0.2 to 1.2 AMPS.

SEAL KIT: Buna "N": SKN-1022, SKN-1032

VITON: SKV-1022, SKV-1032

INSTALLATION: No restrictions.

WEIGHT: 4.58 lbs [2,09 kg]. aluminum body.

7.65 lbs [3,48 kg]. steel body.

info.el@bucherhydraulics.com

www.bucherhydraulics.com/commoncavity

© 2015 by Bucher Hydraulics, Inc., 2545 Northwest Parkway, Elgin, Illinois 60124, USA

All rights reserved.

The technical information in this catalog, may contain calculated figures (for reference only) and not actual performance data for this product.

Data is provided for the purpose of product description only, and must not be construed as warranted characteristics in the legal sense.

The information does not relieve users from the duty of conducting their own evaluations and tests. Because the products are subject to continual improvement, we reserve the right to amend the product specifications contained in this catalogue.

PRESSURE COMPENSATED, NORMALLY CLOSED OR NORMALLY OPEN PROPORTIONAL, IN-LINE FLOW CONTROL VALVE.

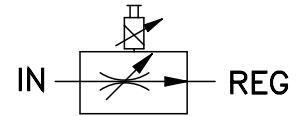

UL approved coil, IP68 and IP69K rated when used with waterproof connector.

LIMITED RANGE ADJUSTMENT (SCREW TYPE)

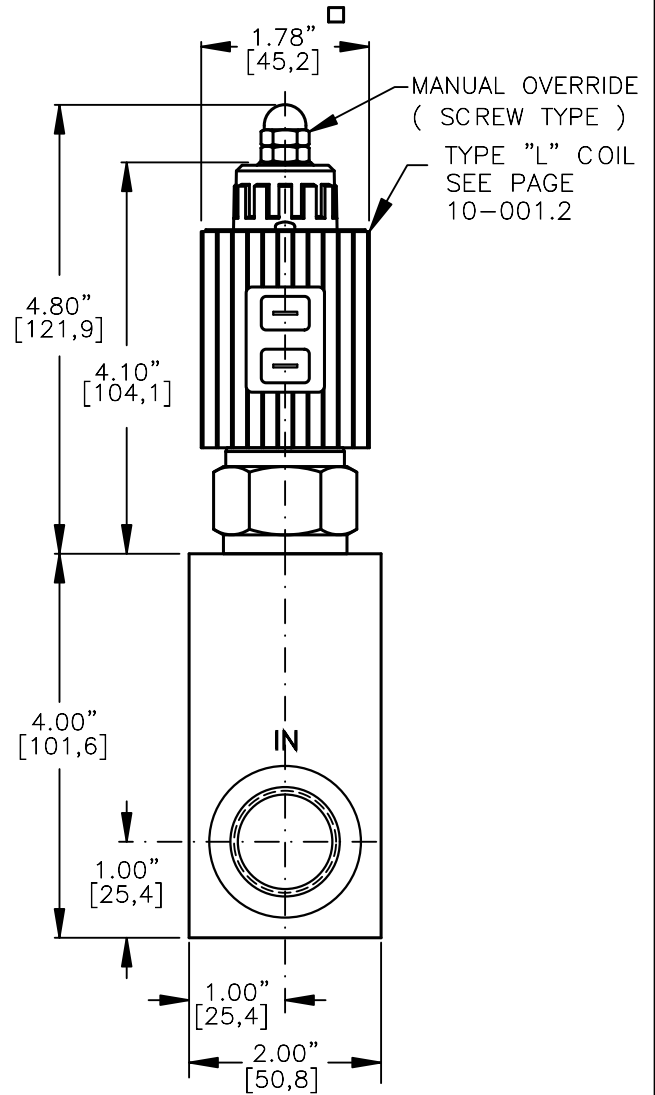
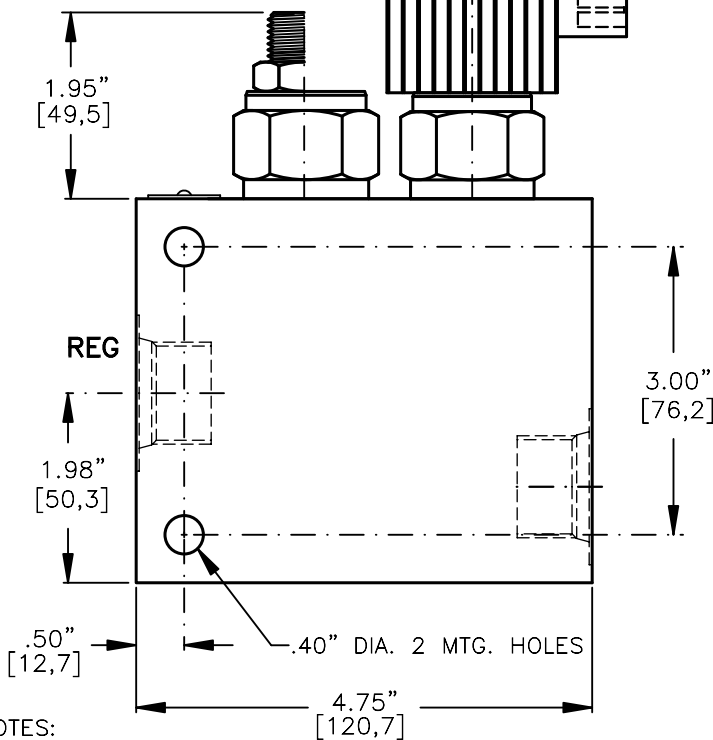

MANUAL OVERRIDE (SCREW TYPE)
TYPE "L" COIL
SEE PAGE 10-001.2

NOTES:
1. SOLENOIDS AVAILABLE WITH DIODES - CONSULT FACTORY.

PIFC-12-X-X-XX-X-X-X-XXX-XXX X

BASIC
SIZE
12=1.062"-12UNF

SEALS
N = BUNA "N"
V = VITON

STYLE
C = NORMALLY CLOSED
O = NORMALLY OPEN

REGULATED FLOW
06 = 0 TO 6.0 GPM
12 = 0 TO 12.0 GPM
18 = 0 TO 18.0 GPM
24 = 0 TO 24.0 GPM

TERMINALS
L = 18GA. 24" LEADS
T = SPADE TERM.
B = BOLT TERM.
G = DIN43650
W = WEATHER-PACK
D = DEUTSCH-DT04-2P
M = METRI-PACK CONN.

VOLTAGE AMPS
12D = 12 VDC 3.00
24D = 24 VDC 1.50

ADJUSTMENT OPTIONS
O-F-100 = NONE
M-F-100 = MANUAL OVERRIDE
O-S-160 = LIMITED RANGE ADJ
M-S-160 = BOTH MO/LTD ADJ

PORTS
12TX = SAE - #12
"A" = ALUM. HOUSING
"S" = STEEL HOUSING

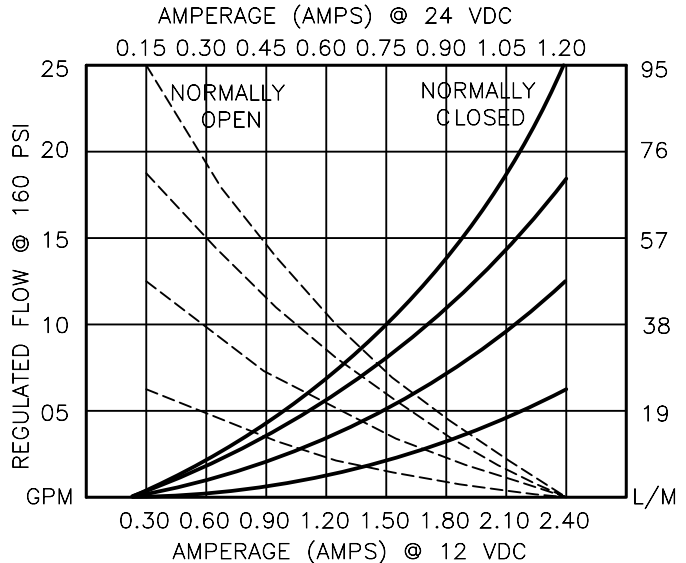

PRESSURE COMPENSATED, PROPORTIONAL, IN-LINE, FLOW CONTROL VALVE.**DESCRIPTION**

This valve is an electro-hydraulic, proportional, in-line (Restrictive) type, pressure compensated, hydraulic flow control. Regulated flow Normally Closed 0 to 24.0 GPM, [0 to 91,2 L/M] max. Normally Open 24.0 to 0 GPM [91,2 to 0 L/M] is proportional to the current input, regardless of load or system pressure.

OPERATIONS

This unit is a direct acting (NO PILOT FLOW), electro-hydraulic, proportional, pressure compensated, flow control valve. When the coil is energized the armature moves the metering orifice open or close against a precision bias spring varying the flow. A pressure compensator spool (HYDROSTAT) modulates the flow at 160 PSI/11,0 Bar delta "P" providing the valve with a constant regulated flow regardless of load or system pressure. When current is increased or decreased to the coil; the flow will increase or decrease proportionally.

IN THE EVENT OF POWER FAILURE THE VALVE WILL CLOSE OR OPEN RESPECTIVELY.

FEATURES AND BENEFITS

Continuous-duty, very low heat rise & waterproof solenoid coil.
Interchangeable solenoid coils & terminations options available.
Hardened precision fitted spool & sleeve provides reliable, long life.
Very efficient wet – armature solenoid core tube construction.
All external carbon steel parts are plated for longer life against the elements.
All valves are 100% functionally tested.

PRESSURE COMPENSATED, PROPORTIONAL, IN-LINE, FLOW CONTROL VALVE.

SPECIFICATIONS

OPERATING PRESSURE: 5,000 PSI [350 Bar]

PROOF PRESSURE: 10,000 PSI [700 Bar]

REGULATED FLOW: 24.0 GPM [90,7 L/M] Max. See performance chart.

INTERNAL LEAKAGE: 30 cu.in/min [495 cc/m] @ 5,000 PSI [350 Bar]

VALVE HOUSINGS: 2500 PSI [175 Bar] = Aluminum – Anodized.

5000 PSI [350 Bar] = Steel – Unplated.

OPERATING TEMPERATURE: -40° to +250° F. [-40° to +120° C.]

OPERATING MEDIA: All general purpose hydraulic fluids such as

MIL-H-5606, SAE-#10, SAE-#20, etc.

RESPONSE: The most efficient method to control this valve is with current control and a 50 Hz dither.

POWER REQUIREMENTS: 12 VDC, Operating current 0.4 to 2.4 AMPS.

24 VDC, Operating current 0.2 to 1.2 AMPS.

SEAL KIT: Buna "N": SKN-1222, SKN-1232

VITON: SKV-1222, SKV-1232

INSTALLATION: No restrictions.

WEIGHT: 5.52 lbs [2,51 kg]. aluminum body.

15.60 lbs [7,10 kg]. steel body.

info.el@bucherhydraulics.com

www.bucherhydraulics.com/commoncavity

© 2015 by Bucher Hydraulics, Inc., 2545 Northwest Parkway, Elgin, Illinois 60124, USA

All rights reserved.

The technical information in this catalog, may contain calculated figures (for reference only) and not actual performance data for this product.

Data is provided for the purpose of product description only, and must not be construed as warranted characteristics in the legal sense.

The information does not relieve users from the duty of conducting their own evaluations and tests. Because the products are subject to continual improvement, we reserve the right to amend the product specifications contained in this catalogue.

PRESSURE COMPENSATED, NORMALLY CLOSED OR NORMALLY OPEN PROPORTIONAL, IN-LINE FLOW CONTROL VALVE.

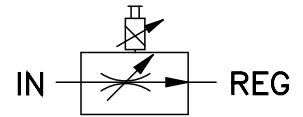

UL approved coil, IP68 and IP69K rated when used with waterproof connector.

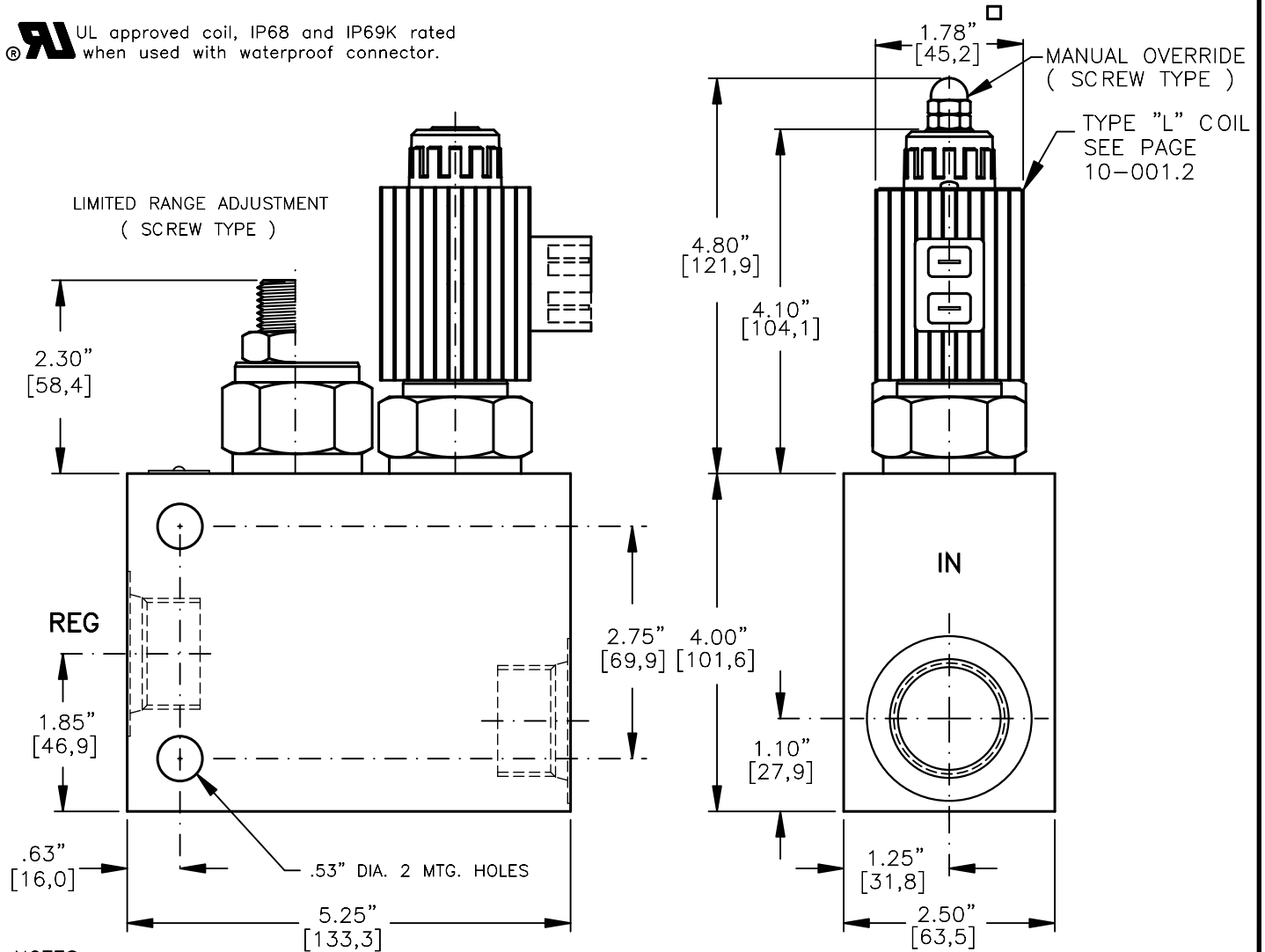

NOTES:
1) SOLENOIDS AVAILABLE WITH DIODES - CONSULT FACTORY.

PIFC-16-X-X-XX-X-X-X-XXX-XXX X

BASIC
SIZE
16=1.312"-12UNF

SEALS
N = BUNA "N"
V = VITON

STYLE
C = NORMALLY CLOSED
O = NORMALLY OPEN

REGULATED FLOW
06 = 0 TO 6.0 GPM
12 = 0 TO 12.0 GPM
18 = 0 TO 18.0 GPM
24 = 0 TO 24.0 GPM
30 = 0 TO 30.0 GPM
36 = 0 TO 36.0 GPM 2)

TERMINALS
L = 18GA. 24" LEADS
T = SPADE TERM.
B = BOLT TERM.
G = DIN43650
W = WEATHER-PACK
D = DEUTSCH-DT04-2P
M = METRI-PACK CONN.

VOLTAGE AMPS
12D = 12 VDC 3.00
24D = 24 VDC 1.50

ADJUSTMENT OPTIONS
O-F-100 = NONE
M-F-100 = MANUAL OVERRIDE
O-S-180 = LIMITED RANGE ADJ.
M-S-180 = BOTH MO/LTD ADJ.

PORTS
16TX = SAE - #16
"A" = ALUM. HOUSING
"S" = STEEL HOUSING

NOTES:
2) AVAILABLE ONLY IN STYLE C (NORMALLY CLOSED)

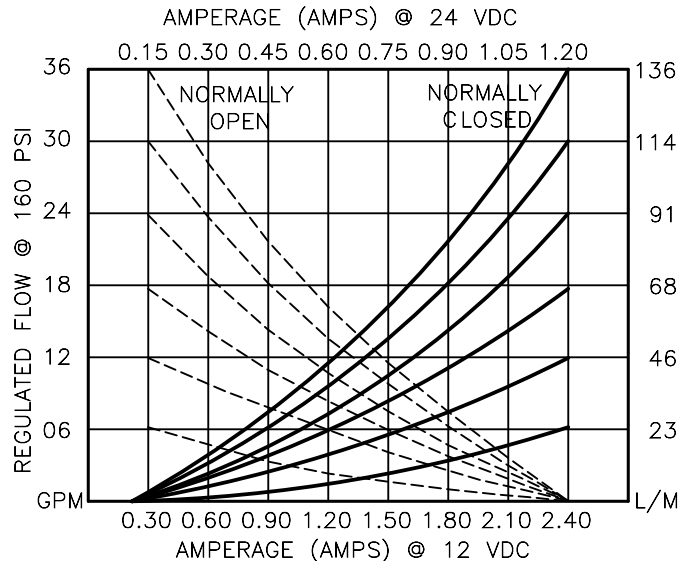

PRESSURE COMPENSATED, PROPORTIONAL, IN-LINE, FLOW CONTROL VALVE.

DESCRIPTION

This valve is an electro-hydraulic, proportional, in-line (Restrictive) type, pressure compensated, hydraulic flow control. Regulated flow Normally Closed 0 to 36.0 GPM, [0 to 137,0 L/M] max. Normally Open 36.0 to 0 GPM [137,0 to 0 L/M] is proportional to the current input, regardless of load or system pressure.

OPERATIONS

This unit is a direct acting (NO PILOT FLOW), electro-hydraulic, proportional, pressure compensated, flow control valve. When the coil is energized the armature moves the metering orifice open or close against a precision bias spring varying the flow. A pressure compensator spool (HYDROSTAT) modulates the flow at 160 PSI/11,0 Bar delta "P" providing the valve with a constant regulated flow regardless of load or system pressure. When current is increased or decreased to the coil; the flow will increase or decrease proportionally.

IN THE EVENT OF POWER FAILURE THE VALVE WILL CLOSE OR OPEN RESPECTIVELY.

FEATURES AND BENEFITS

Continuous-duty, very low heat rise & waterproof solenoid coil.

Interchangeable solenoid coils & terminations options available.

Hardened precision fitted spool & sleeve provides reliable, long life.

Very efficient wet - armature solenoid core tube construction.

All external carbon steel parts are plated for longer life against the elements.

All valves are 100% functionally tested.

PRESSURE COMPENSATED, PROPORTIONAL, IN-LINE, FLOW CONTROL VALVE.

SPECIFICATIONS

OPERATING PRESSURE: 5,000 PSI [350 Bar]

PROOF PRESSURE: 10,000 PSI [700 Bar]

REGULATED FLOW: 36.0 GPM [136,0 L/M] Max. See performance chart.

INTERNAL LEAKAGE: 40 cu.in/min [660 cc/m] @ 5,000 PSI [350 Bar]

VALVE HOUSINGS: 2500 PSI [175 Bar] = Aluminum - Anodized.

5000 PSI [350 Bar] = Steel - Unplated.

OPERATING TEMPERATURE: -40° to +250° F. [-40° to +120° C.]

OPERATING MEDIA: All general purpose hydraulic fluids such as

MIL-H-5606, SAE-#10, SAE-#20, etc.

RESPONSE: The most efficient method to control this valve is with current control and a 50 Hz dither.

POWER REQUIREMENTS: 12 VDC, Operating current 0.4 to 2.4 AMPS.

24 VDC, Operating current 0.2 to 1.2 AMPS.

SEAL KIT: Buna "N": SKN-1622, SKN-1632

VITON: SKV-1622, SKV-1632

INSTALLATION: No restrictions.

WEIGHT: 7.42 lbs [3,37 kg]. aluminum body.

21.70 lbs [9,86 kg]. steel body.

PRESSURE COMPENSATED, NORMALLY CLOSED OR NORMALLY OPEN PROPORTIONAL, PRIORITY FLOW CONTROL VALVE.

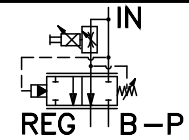

UL approved coil, IP68 and IP69K rated when used with waterproof connector.

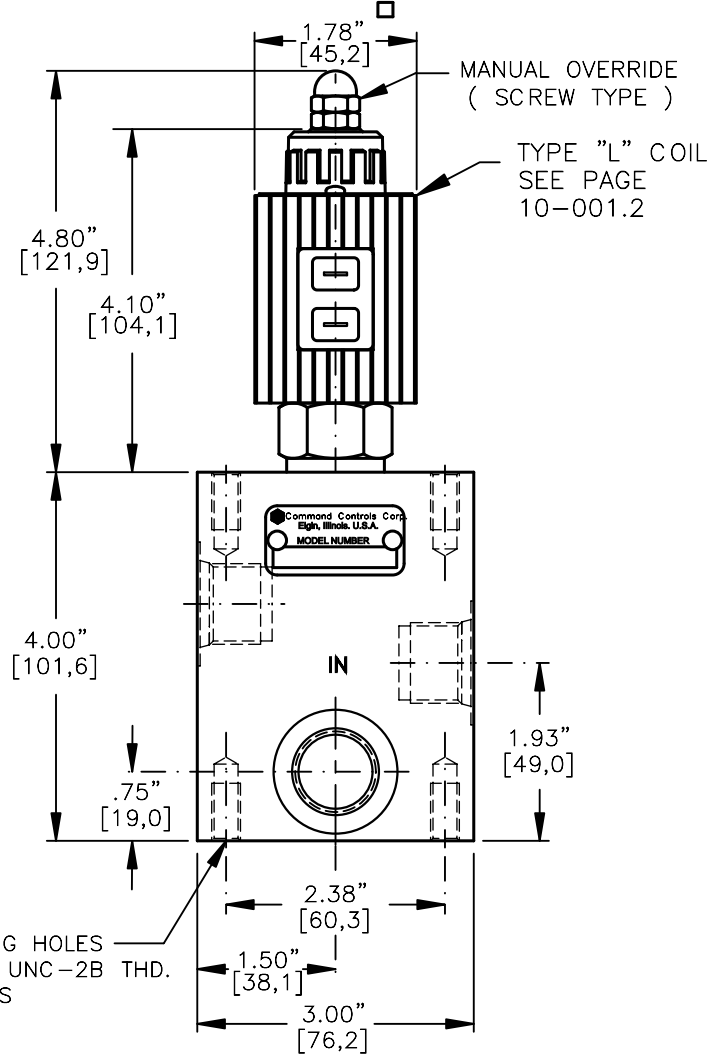
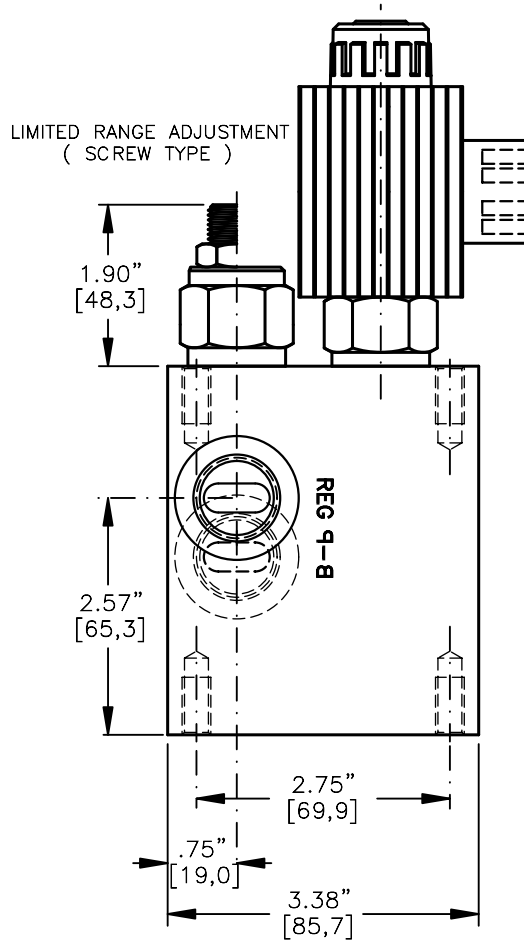

NOTES:
1. SOLENOIDS AVAILABLE WITH DIODES - CONSULT FACTORY.

PBFC-10-X-X-XX-X-X-X-XXX-XXX X

BASIC
SIZE
10 = 7/8"-14UNF

SEALS
N = BUNA "N"
V = VITON

STYLE
C = NORMALLY CLOSED
O = NORMALLY OPEN

REGULATED FLOW
04 = 0 TO 4.0 GPM
08 = 0 TO 8.0 GPM
12 = 0 TO 12.0 GPM
16 = 0 TO 16.0 GPM

TERMINALS
L = 18GA. 24" LEADS
T = SPADE TERM.
B = BOLT TERM.
G = DIN43650
W = WEATHER-PACK
D = DEUTSCH-DT04-2P
M = METRI-PACK CONN.

VOLTAGE AMPS
12D = 12 VDC 3.00
24D = 24 VDC 1.50

ADJUSTMENT OPTIONS
O-F-100 = NONE
M-F-100 = MANUAL OVERRIDE
O-S-160 = LIMITED RANGE ADJ.
M-S-160 = BOTH MO/LTD ADJ.

PORTS
10TX = SAE - #10
"A" = ALUM. HOUSING
"S" = STEEL HOUSING

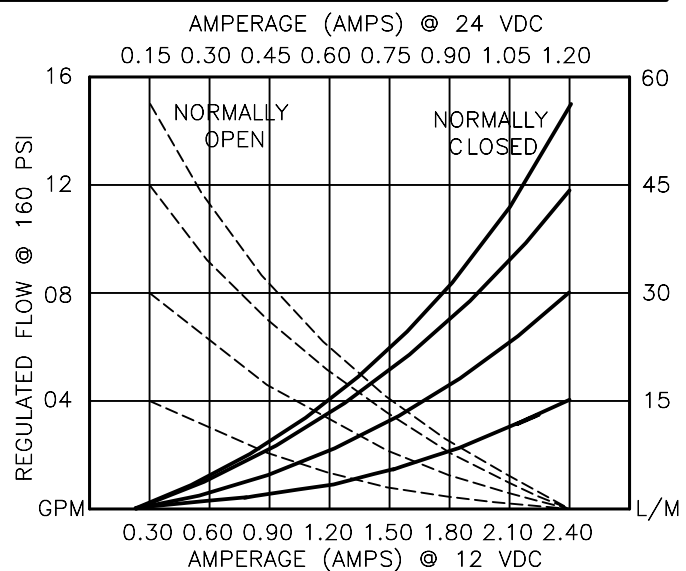

PRESSURE COMPENSATED, PROPORTIONAL, PRIORITY FLOW CONTROL VALVE.**DESCRIPTION**

This valve is an electro-hydraulic, proportional, priority (By-Pass) type, pressure compensated, hydraulic flow control. Regulated flow normally closed 0 to 16.0 GPM [0 to 61,0 L/m] or normally open 16.0 to 0 GPM [61,0 to 0 L/m] @ 160 PSI DELTA P. is proportional to the current input regardless of load or system pressure. After the priority flow is satisfied the excess flow is diverted to a secondary circuit or to tank. Maximum inlet flow is 25.0 GPM [95,0 L/m].

OPERATIONS

This unit is a direct acting (NO PILOT FLOW), electro-hydraulic, proportional, pressure compensated, flow control valve. When the coil is energized the armature moves the metering orifice open or closed against a precision bias spring varying the flow. A pressure compensator spool (HYDROSTAT) modulates the flow at 160 PSI/11,0 Bar delta "P" providing pressure. When current is increased or decreased to the coil; the flow will increase or decrease proportionally.

IN THE EVENT OF POWER FAILURE THE VALVE WILL CLOSE OR OPEN RESPECTIVELY.

FEATURES AND BENEFITS

Continuous-duty, very low heat rise & waterproof solenoid coil.

Interchangeable solenoid coils & terminations options available.

Hardened precision fitted spool & sleeve provides reliable, long life.

Very efficient wet - armature solenoid core tube construction.

All external carbon steel parts are plated for longer life against the elements.

All valves are 100% functionally tested.

PRESSURE COMPENSATED, PROPORTIONAL, PRIORITY FLOW CONTROL VALVE.**SPECIFICATIONS**

OPERATING PRESSURE: 5,000 PSI [350 Bar]

PROOF PRESSURE: 10,000 PSI [700 Bar]

REGULATED FLOW: 16.0 GPM [61,0 L/m] Max. See performance chart.

INTERNAL LEAKAGE: 20 cu.in/min [330 cc/m] @ 5,000 PSI [350 Bar]

VALVE HOUSINGS: 2500 PSI [175 Bar] = Aluminum – Anodized.

5000 PSI [350 Bar] = Steel – Unplated.

OPERATING TEMPERATURE: -40° to +250° F. [-40° to +120° C.]

OPERATING MEDIA: All general purpose hydraulic fluids such as

MIL-H-5606, SAE-#10, SAE-#20, etc.

RESPONSE: The most efficient method to control this valve is with current control and a 50 Hz dither.

POWER REQUIREMENTS: 12 VDC, Operating current 0.4 to 2.4 AMPS.

24 VDC, Operating current 0.2 to 1.2 AMPS.

SEAL KIT: Buna "N": SKN-1022, SKN-1042

VITON: SKV-1022, SKV-1042

INSTALLATION: No restrictions.

WEIGHT: 4.58 lbs [2,09 kg]. aluminum body.

7.65 lbs [3,48 kg]. steel body.

info.el@bucherhydraulics.com

www.bucherhydraulics.com/commoncavity

© 2015 by Bucher Hydraulics, Inc., 2545 Northwest Parkway, Elgin, Illinois 60124, USA

All rights reserved.

The technical information in this catalog, may contain calculated figures (for reference only) and not actual performance data for this product.

Data is provided for the purpose of product description only, and must not be construed as warranted characteristics in the legal sense.

The information does not relieve users from the duty of conducting their own evaluations and tests. Because the products are subject to continual improvement, we reserve the right to amend the product specifications contained in this catalogue.

PRESSURE COMPENSATED, NORMALLY CLOSED OR NORMALLY OPEN PROPORTIONAL, PRIORITY FLOW CONTROL VALVE.

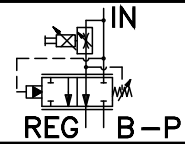

UL approved coil, IP68 and IP69K rated when used with waterproof connector.

LIMITED RANGE ADJUSTMENT (SCREW TYPE)

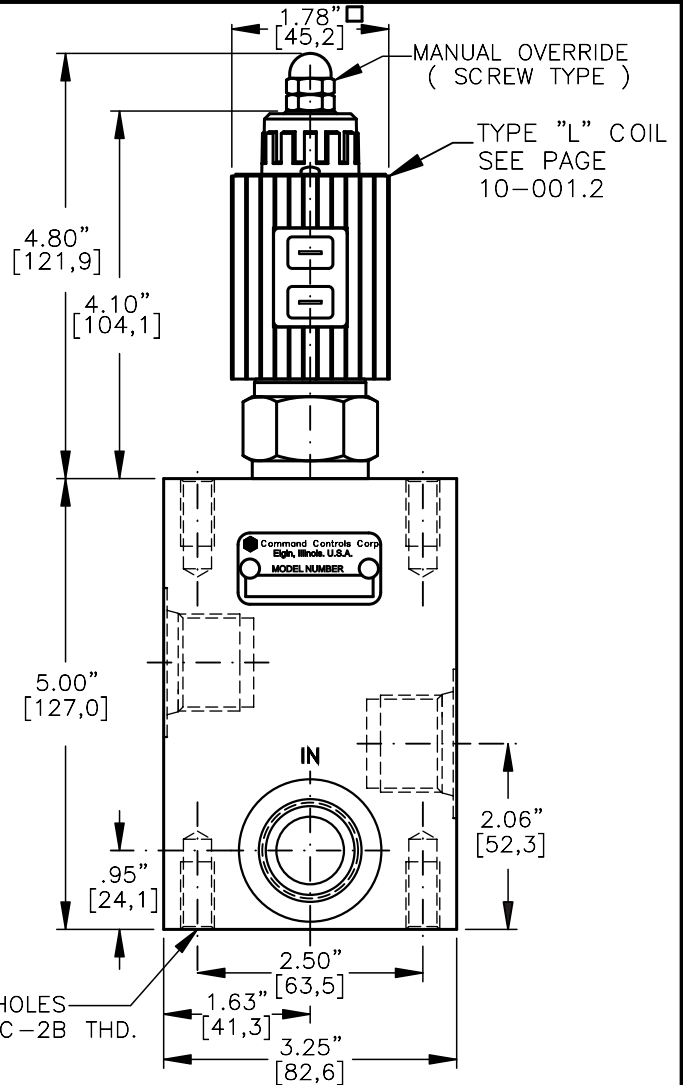
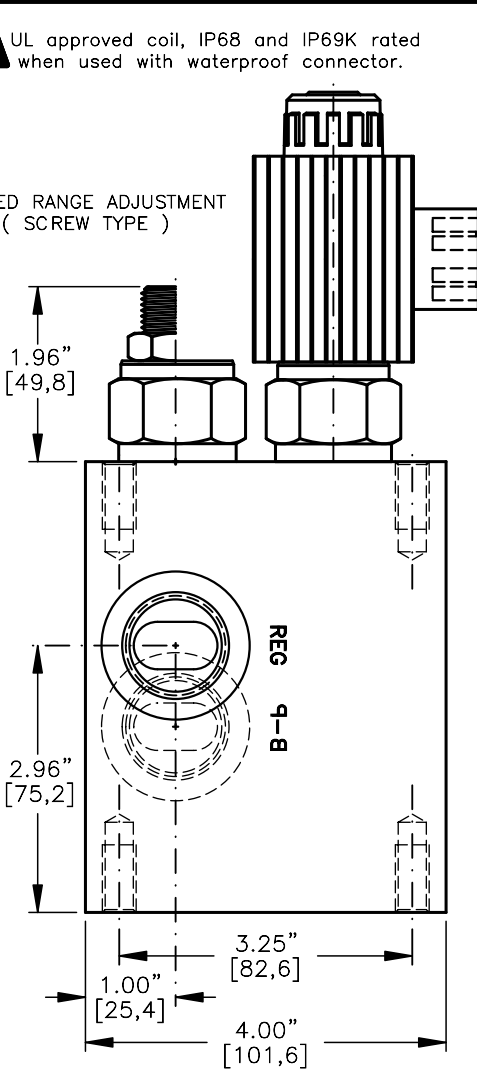

4 MOUNTING HOLES
3/8"-16 UNC-2B THD.
BOTH ENDS.

NOTES:

1. SOLENOIDS AVAILABLE WITH DIODES - CONSULT FACTORY.

PBFC-12-X-X-XX-X-X-X-XXX-XXX X

BASIC

SIZE
12=1.062"-12UNF

SEALS
N = BUNA "N"
V = VITON

STYLE
C = NORMALLY CLOSED
O = NORMALLY OPEN

REGULATED FLOW
06 = 0 TO 6.0 GPM
12 = 0 TO 12.0 GPM
18 = 0 TO 18.0 GPM
24 = 0 TO 24.0 GPM

TERMINALS

L = 18GA. 24" LEADS
T = SPADE TERM.
B = BOLT TERM.
G = DIN43650
W = WEATHER-PACK
D = DEUTSCH-DT04-2P
M = METRI-PACK CONN.
VOLTAGE AMPS
12D = 12 VDC 3.00
24D = 24 VDC 1.50

ADJUSTMENT OPTIONS

O-F-100 = NONE
M-F-100 = MANUAL OVERRIDE
O-S-160 = LIMITED RANGE ADJ.
M-S-160 = BOTH MO/LTD ADJ.

PORTS

12TX = SAE - #12
"A" = ALUM. HOUSING
"S" = STEEL HOUSING

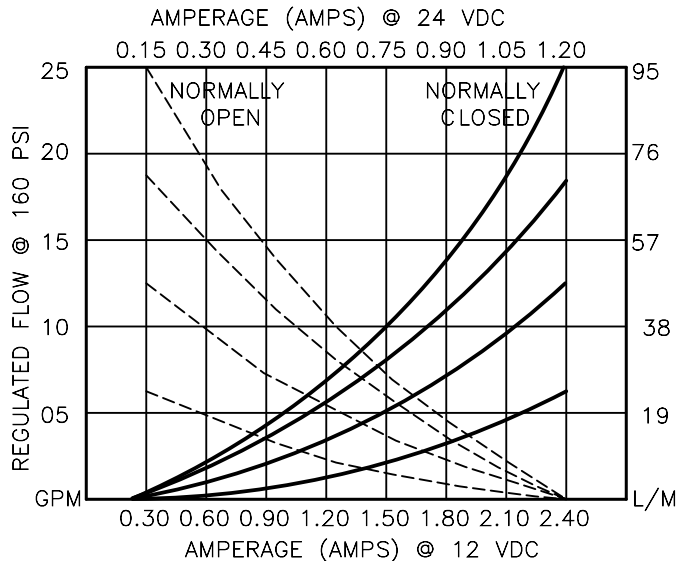

PRESSURE COMPENSATED, PROPORTIONAL, PRIORITY FLOW CONTROL VALVE.**DESCRIPTION**

This valve is an electro-hydraulic, proportional, priority (By-Pass) type, pressure compensated, hydraulic flow control. Regulated flow normally closed 0 to 24.0 GPM [0 to 91,2 L/M] or normally open 24.0 to 0 GPM [91,2 to 0 L/M] @ 160 PSI DELTA P. is proportional to the current input regardless of load or system pressure. After the priority flow is satisfied the excess flow is diverted to a secondary circuit or to tank. Maximum inlet flow is 35.0 GPM [130,0 L/M].

OPERATIONS

This unit is a direct acting (NO PILOT FLOW), electro-hydraulic, proportional, pressure compensated, flow control valve. When the coil is energized the armature moves the metering orifice open or closed against a precision bias spring varying the flow. A pressure compensator spool (HYDROSTAT) modulates the flow at 160 PSI/11,0 Bar delta "P" providing pressure. When current is increased or decreased to the coil; the flow will increase or decrease proportionally.

IN THE EVENT OF POWER FAILURE THE VALVE WILL CLOSE OR OPEN RESPECTIVELY.

FEATURES AND BENEFITS

Continuous-duty, very low heat rise & waterproof solenoid coil.

Interchangeable solenoid coils & terminations options available.

Hardened precision fitted spool & sleeve provides reliable, long life.

Very efficient wet – armature solenoid core tube construction.

All external carbon steel parts are plated for longer life against the elements.

All valves are 100% functionally tested.

PRESSURE COMPENSATED, PROPORTIONAL, PRIORITY FLOW CONTROL VALVE.**SPECIFICATIONS**

OPERATING PRESSURE: 5,000 PSI [350 Bar]

PROOF PRESSURE: 10,000 PSI [700 Bar]

REGULATED FLOW: 24.0 GPM [91,2 l/m] Max. See performance chart.

INTERNAL LEAKAGE: 30 cu.in/min [495 cc/m] @ 5,000 PSI [350 Bar]

VALVE HOUSINGS: 2500 PSI [175 Bar] = Aluminum – Anodized.

5000 PSI [350 Bar] = Steel – Unplated.

OPERATING TEMPERATURE: -40° to +250° F. [-40° to +120° C.]

OPERATING MEDIA: All general purpose hydraulic fluids such as

MIL-H-5606, SAE-#10, SAE-#20, etc.

RESPONSE: The most efficient method to control this valve is with current control and a 50 Hz dither.

POWER REQUIREMENTS: 12 VDC, Operating current 0.4 to 2.4 AMPS.

24 VDC, Operating current 0.2 to 1.2 AMPS.

SEAL KIT: Buna "N": SKN-1222, SKN-1242

VITON: SKV-1222, SKV-1242

INSTALLATION: No restrictions.

WEIGHT: 5.58 lbs [2,54 kg]. aluminum body.

9.65 lbs [4,38 kg]. steel body.

info.el@bucherhydraulics.com

www.bucherhydraulics.com/commoncavity

© 2015 by Bucher Hydraulics, Inc., 2545 Northwest Parkway, Elgin, Illinois 60124, USA

All rights reserved.

The technical information in this catalog, may contain calculated figures (for reference only) and not actual performance data for this product.

Data is provided for the purpose of product description only, and must not be construed as warranted characteristics in the legal sense.

The information does not relieve users from the duty of conducting their own evaluations and tests. Because the products are subject to continual improvement, we reserve the right to amend the product specifications contained in this catalogue.

PRESSURE COMPENSATED, NORMALLY CLOSED OR NORMALLY OPEN PROPORTIONAL, PRIORITY FLOW CONTROL VALVE.

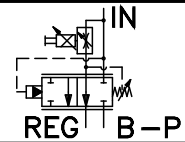

UL approved coil, IP68 and IP69K rated when used with waterproof connector.

LIMITED RANGE ADJUSTMENT (SCREW TYPE)

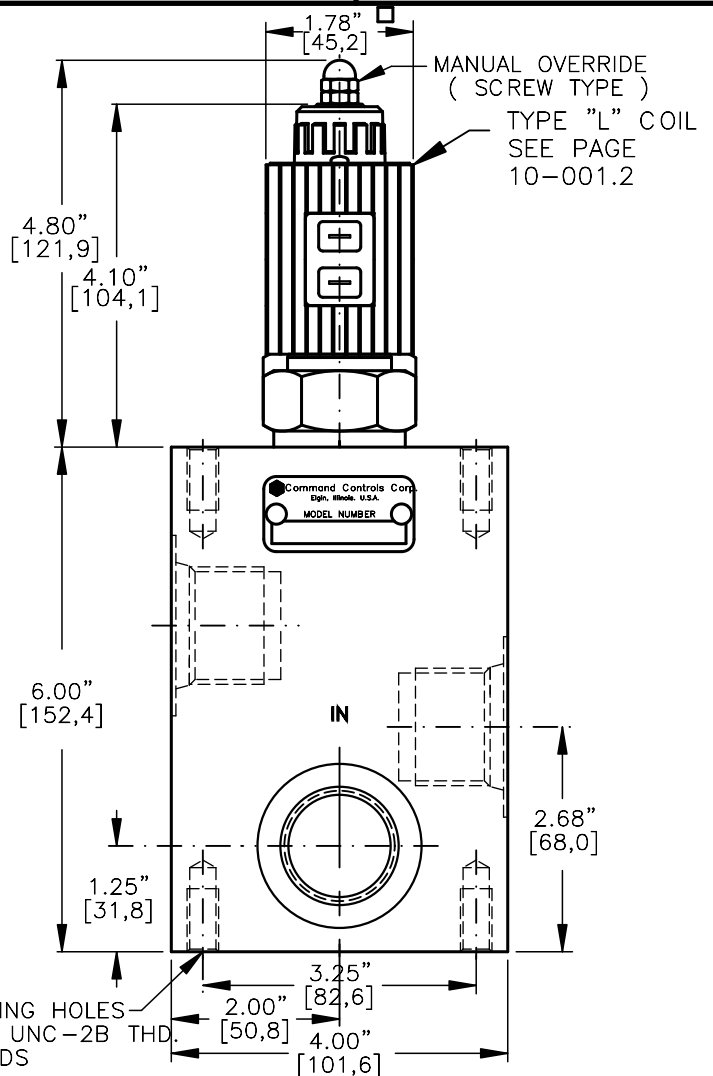
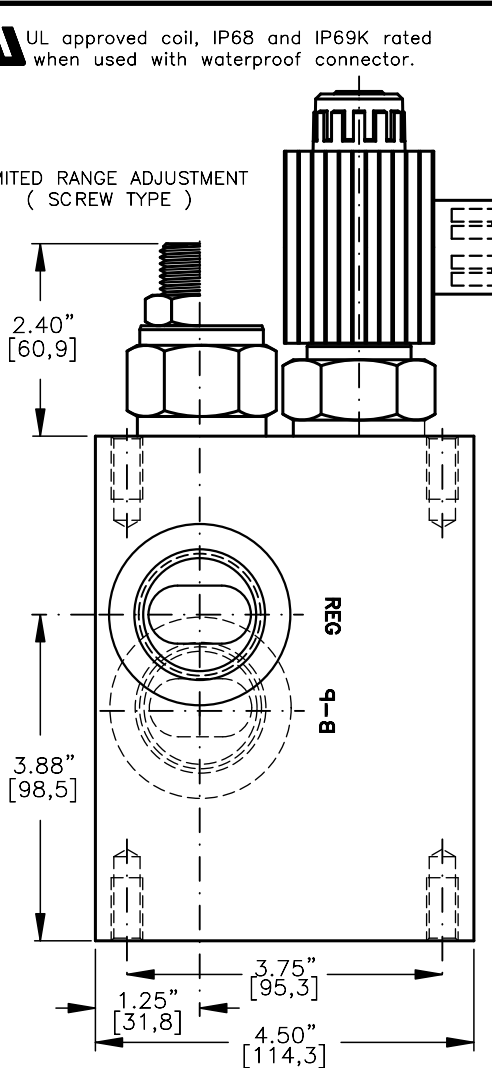

4 MOUNTING HOLES
3/8"-16 UNC-2B THD.
BOTH ENDS

NOTES:

1) SOLENOIDS AVAILABLE WITH DIODES - CONSULT FACTORY.

PBFC-16-X-X-XX-X-X-X-XXX-XXX X

BASIC

SIZE

16= 1.312"-12UNF

SEALS

N = BUNA "N"

V = VITON

STYLE

C = NORMALLY CLOSED

O = NORMALLY OPEN

REGULATED FLOW

06 = 0 TO 6.0 GPM

12 = 0 TO 12.0 GPM

18 = 0 TO 18.0 GPM

24 = 0 TO 24.0 GPM

30 = 0 TO 30.0 GPM

36 = 0 TO 36.0 GPM ²⁾

NOTES:

2) AVAILBE ONLY IN STYLE C (NORMALLY CLOSED)

TERMINALS

L = 18GA. 24" LEADS

T = SPADE TERM.

B = BOLT TERM.

G = DIN43650

W = WEATHER-PACK

D = DEUTSCH-DT04-2P

M = METRI-PACK CONN.

VOLTAGE AMPS

12D = 12 VDC 3.00

24D = 24 VDC 1.50

ADJUSTMENT OPTIONS

O-F-100 = NONE

M-F-100 = MANUAL OVERRIDE

O-S-180 = LIMITED RANGE ADJ.

M-S-180 = BOTH MO/LTD ADJ.

PORTS

16TX = SAE - #16

"A" = ALUM. HOUSING

"S" = STEEL HOUSING

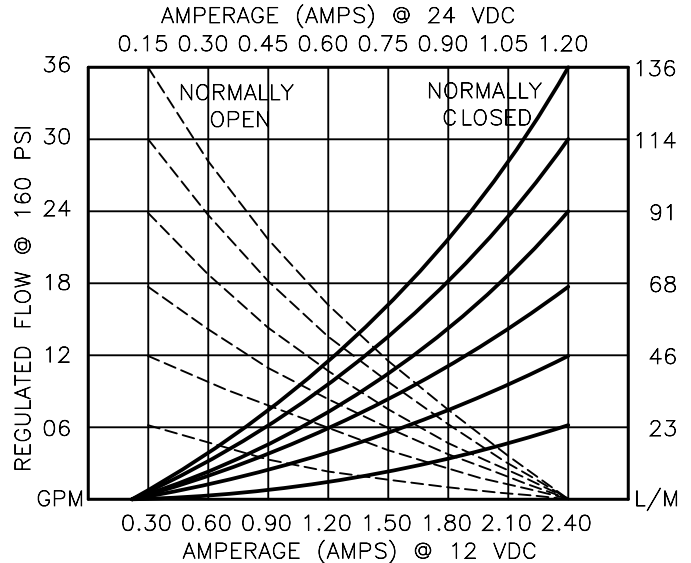

PRESSURE COMPENSATED, PROPORTIONAL, PRIORITY FLOW CONTROL VALVE.**DESCRIPTION**

This valve is an electro-hydraulic, proportional, priority (By-Pass) type, pressure compensated, hydraulic flow control. Regulated flow normally closed 0 to 36.0 GPM [0 to 136,8 L/M] or normally open 36.0 to 0 GPM [136,8 to 0 L/M] @ 160 PSI DELTA P. is proportional to the current input regardless of load or system pressure. After the priority flow is satisfied the excess flow is diverted to a secondary circuit or to tank. Maximum inlet flow is 50.0 GPM [190,0 L/M].

OPERATIONS

This unit is a direct acting (NO PILOT FLOW), electro-hydraulic, proportional, pressure compensated, flow control valve. When the coil is energized the armature moves the metering orifice open or closed against a precision bias spring varying the flow. A pressure compensator spool (HYDROSTAT) modulates the flow at 160 PSI/11,0 Bar delta "P" providing pressure. When current is increased or decreased to the coil; the flow will increase or decrease proportionally.

IN THE EVENT OF POWER FAILURE THE VALVE WILL CLOSE OR OPEN RESPECTIVELY.

FEATURES AND BENEFITS

Continuous-duty, very low heat rise & waterproof solenoid coil.

Interchangeable solenoid coils & terminations options available.

Hardened precision fitted spool & sleeve provides reliable, long life.

Very efficient wet - armature solenoid core tube construction.

All external carbon steel parts are plated for longer life against the elements.

All valves are 100% functionally tested.

PRESSURE COMPENSATED, PROPORTIONAL, PRIORITY FLOW CONTROL VALVE.

SPECIFICATIONS

OPERATING PRESSURE: 5,000 PSI [350 Bar]

PROOF PRESSURE: 10,000 PSI [700 Bar]

REGULATED FLOW: 36.0 GPM [136,8 l/m] Max. See performance chart.

INTERNAL LEAKAGE: 40 cu.in/min [660 cc/m] @ 5,000 PSI [350 Bar]

VALVE HOUSINGS: 2500 PSI [175 Bar] = Aluminum – Anodized.

5000 PSI [350 Bar] = Steel – Unplated.

OPERATING TEMPERATURE: -40° to +250° F. [-40° to +120° C.]

OPERATING MEDIA: All general purpose hydraulic fluids such as

MIL-H-5606, SAE-#10, SAE-#20, etc.

RESPONSE: The most efficient method to control this valve is with
current control and a 50 Hz dither.

POWER REQUIREMENTS: 12 VDC, Operating current 0.4 to 2.4 AMPS.

24 VDC, Operating current 0.2 to 1.2 AMPS.

SEAL KIT: Buna "N": SKN-1622, SKN-1642

VITON: SKV-1622, SKV-1642

INSTALLATION: No restrictions.

WEIGHT: 6.78 lbs [2,54 kg] aluminum body.

9.89 lbs [4,50 kg] steel body.

PWM MICRO PROPORTIONAL VALVE DRIVER

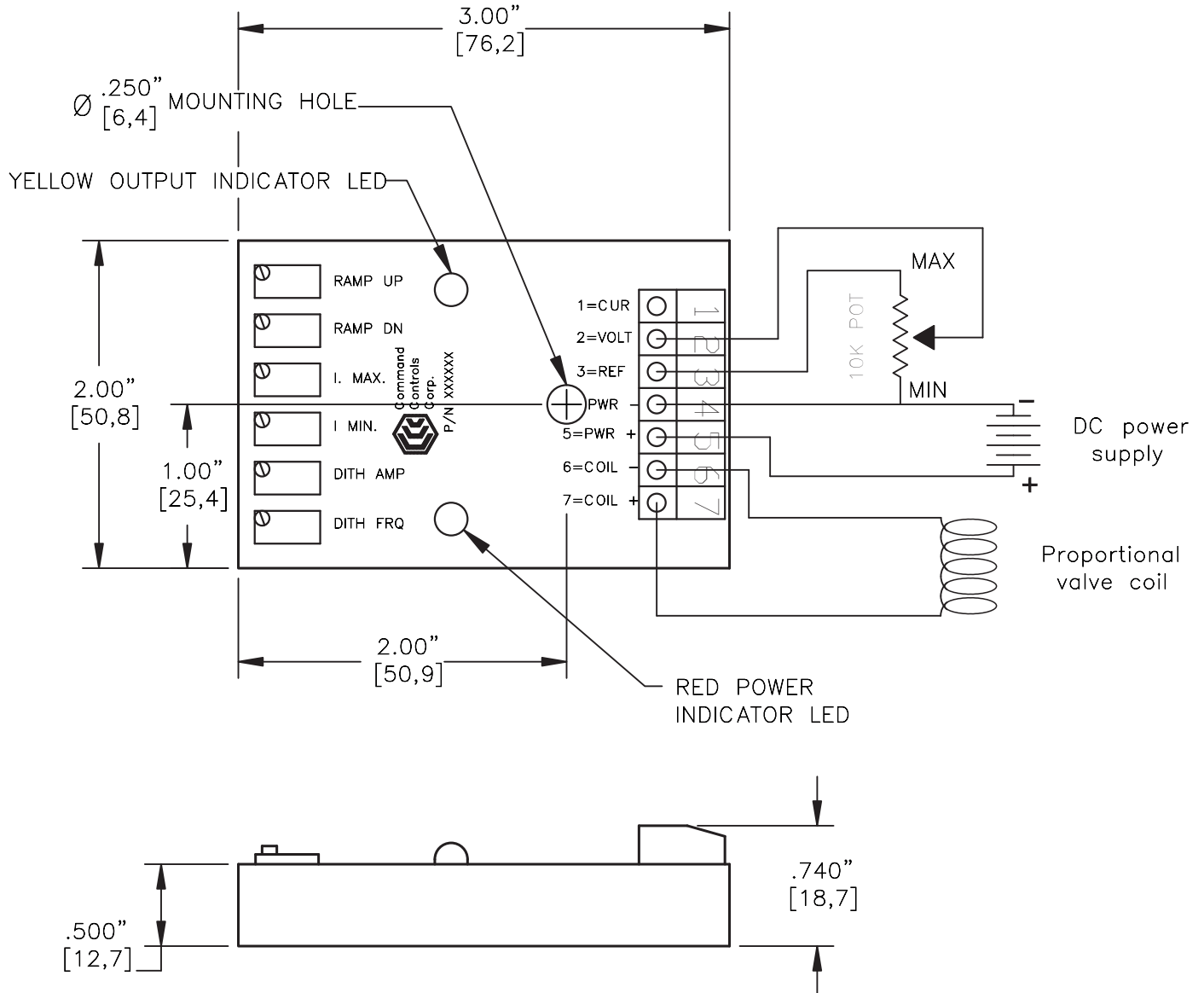

PWM-1400-12..... for use with 12 V.D.C.

PWM-1400-24..... for use with 24 V.D.C.

PWM MICRO PROPORTIONAL VALVE DRIVER

DESCRIPTION:

The Block Micro Proportional Driver is a electrical circuit built into an epoxy potted enclosure designed to proportionally control the flow of our solenoid valves.

The BMPD provides a $\varnothing 0.25$ [6,4] mounting hole that is built in the body. Assembly of the unit is accomplished by connecting stranded or solid #10 AWG [$\varnothing 3,0$] wire, up to to the miniature header that is provided on the top surface of the block.

Adjustments made to the unit are made by turning the adjustment screws located on the top surface of the block. The block also includes a red power indicator LED and a variable intensity yellow LED, to indicate output level, for onboard diagnostics.

TECHNICAL DATA:

PARAMETER	ALL VERSIONS
SUPPLY VOLTAGE	9.0 V DC min. -32 VDC max.
SUPPLY CURRENT	45 mA max. (no load)
INPUT CONTROL SIGNAL VOLTAGE OR CURRENT	0 – 5 VDC (300 K ohm impedance) 0–20 mA (100 ohm impedance)
RAMPING UP/DOWN TIME	0.1 – 20 sec. linear (+/- 0.1%/°C)
PWM FREQUENCY	1.2 KHz fixed
OUTPUT LEAP TO I MIN	@ 0.1 V or 0.4 mA control (+/- 15%)
DITHERING FREQUENCY	30 – 150 Hz
DITHERING AMPLITUDE	0 – 500 mA peak to peak
VOLTAGE REFERENCE	5.0V +/- 5% regulated
OPERATING TEMP.	-25 to 85 °C

PARAMETER	PWM-1400-12	PWM-1400-24
OUTPUT CURRENT @ 25 °C T _a		
CONTINUOUS	3.0 Amps max.	1.5 Amps max.
PEAK PULSED (16ms)	17.0A max.	4.7A max.
I MIN. (+/- 20%)	0 – 1.0A max.	0 – 0.5A max.
I MAX. (+/- 20%)	I _{min.} + 2.0A max.	I _{min.} + 1.0A max.
REGULATION DV	+/- 0.2% / V	
REGULATION DT	+/- 0.1% / °C	

PWM MICRO PROPORTIONAL VALVE DRIVER

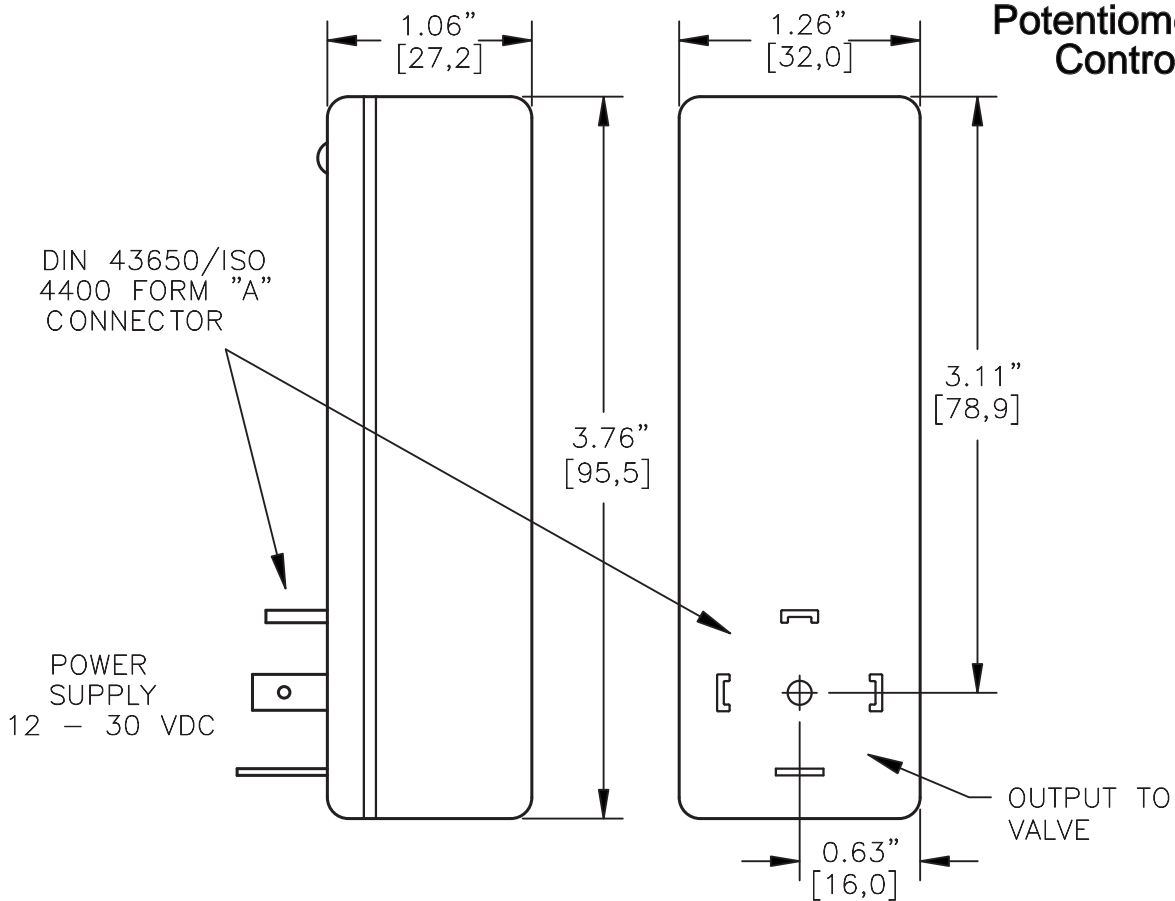
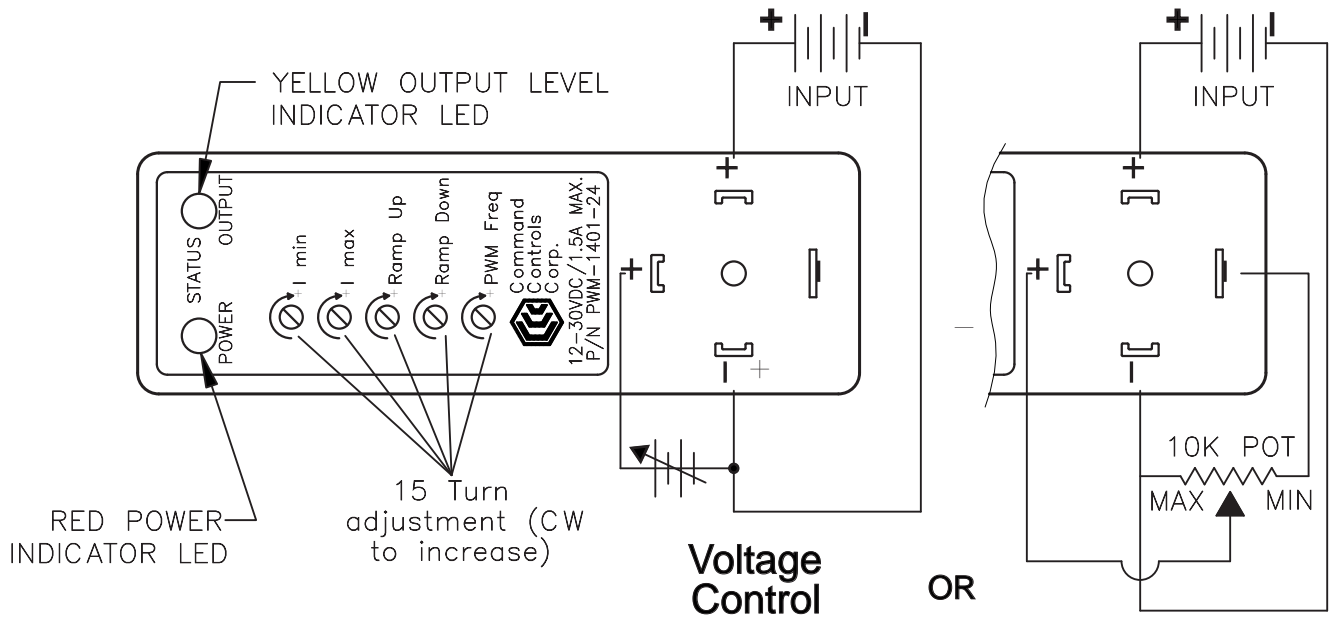

PWM-1401-12..... for use with 12 V.D.C.

PWM-1401-24..... for use with 24 V.D.C.

PWM MICRO PROPORTIONAL VALVE DRIVER

DESCRIPTION:

The Micro Proportional Driver is a coil mounted driver unit used to proportionally control the flow of our solenoid valves.

The electronic circuit for the Micro Proportional Driver is built into an environment resistant miniature enclosure. It incorporates a DIN 43650/ISO 4400 form "A" connector male and female interface, and it is mounted on our coils using a mounting screw.

The case for the driver is made from engineered polymers to resist harsh chemicals, foreign substances, and moisture.

The unit meets NEMA 4 environment standards.

TECHNICAL DATA:

PARAMETER	ALL VERSIONS
SUPPLY VOLTAGE	12 V DC min. – 30 VDC max.
SUPPLY CURRENT	45 mA max. (no load)
INPUT CONTROL SIGNAL	0 – 10 VDC (500 K ohm impedance)
RAMPING UP/DOWN TIME	0.1 – 20 sec. linear (+/- 0.1% / °C)
PWM FREQUENCY	95 – 225 Hz
OUTPUT LEAP TO I MIN	@ 0.2 V or 0.4 mA control (+/- 15%)
OPERATING TEMP.	-25 to 85 °C

PARAMETER	PWM-1401-12	PWM-1401-24
OUTPUT CURRENT @ 25°C T _a		
CONTINUOUS	3.0 Amps max.	1.5 Amps max.
PEAK PULSED (16ms)	17.0A max.	4.7A max.
I MIN. (+/- 20%)	0 – 1.0A max.	0 – 0.5A max.
I MAX. (+/- 20%)	Imin. + 2.0A max.	Imin. + 1.0A max.
REGULATION DV	+/- 0.2% / V	
REGULATION DT	+/- 0.1% / °C	

PWM PROPORTIONAL DRIVER CONTROL BOX

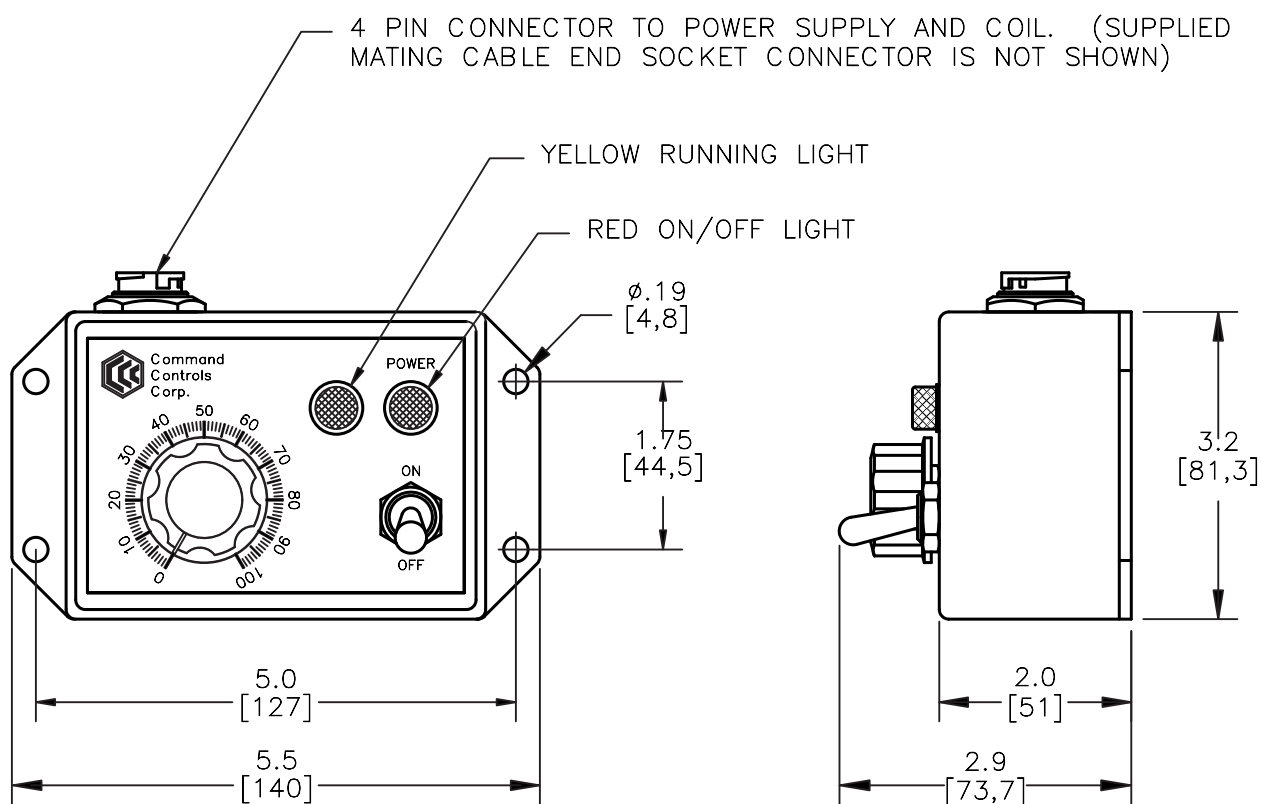

PWM-1404-12..... for use with 12 V.D.C.

PWM-1404-24..... for use with 24 V.D.C.

PWM PROPORTIONAL DRIVER CONTROL BOX

DESCRIPTION:

THE PWM PROPORTIONAL DRIVER CONTROL BOX IS A COMPACT DEVICE, USED TO MANUALLY CONTROL PROPORTIONAL VALVES. IT USES A MICRO PROPORTIONAL DRIVER AND A POTENTIOMETER TO CONTROL THE VOLTAGE OR CURRENT TO THE SOLENOID COIL.

FEATURES INCLUDE A RED AND YELLOW INDICATOR LIGHT FOR ONBOARD DIAGNOSTICS AND A PLASTIC KNOB TO MANUALLY OPERATE THE VALVE.

THE PROPORTIONAL DRIVER CONTROL BOX ALSO INCLUDES A MOUNTING BRACKET WITH FOUR Ø .190 MOUNTING HOLES, FOR EASY MOUNTING.

TECHNICAL DATA:

COMPONENTS	PWM-1404-12	PWM-1404-24
POTENTIOMETER	10K SINGLE TURN TRIMMING POT.	10K SINGLE TURN TRIMMING POT.
LIGHT BULB	28 V INCANDESCENT BULB	28 V INCANDESCENT BULB
TOGGLE SWITCH	SPDT AC RATED GENERAL PURPOSE	SPDT AC RATED GENERAL PURPOSE
PWM DRIVER	PWM-1400-12	PWM-1400-24
RECEPTACLE	4 PIN PLASTIC CONNECTOR	4 PIN PLASTIC CONNECTOR